

BID OF _____

2016

PROPOSAL, CONTRACT, BOND AND SPECIFICATIONS

FOR

RESURFACING 2016 – ASPHALT PAVEMENT PULVERIZING, MILLING & PAVING

CONTRACT NO. 7616

MUNIS NO. 10895

IN

MADISON, DANE COUNTY, WISCONSIN

AWARDED BY THE COMMON COUNCIL
MADISON, WISCONSIN ON _____

CITY ENGINEERING DIVISION
1600 EMIL STREET
MADISON, WISCONSIN 53713

<https://bidexpress.com/login>

**RESURFACING 2016 – ASPHALT PAVEMENT PULVERIZING, MILLING & PAVING
CONTRACT NO. 7616**

INDEX

SECTION A: ADVERTISEMENT FOR BIDS AND INSTRUCTIONS TO BIDDERSA-1
SECTION B: PROPOSAL SECTION.....B-1
SECTION C: SMALL BUSINESS ENTERPRISE C-1
SECTION D: SPECIAL PROVISIONS..... D-1
SECTION E: BIDDER’S ACKNOWLEDGEMENTE-1
SECTION F: DISCLOSURE OF OWNERSHIP & BEST VALUE CONTRACTING.....F-1
SECTION G: BID BOND G-1
SECTION H: AGREEMENT..... H-1
SECTION I: PAYMENT AND PERFORMANCE BONDI-1
SECTION J: PREVAILING WAGE RATES..... J-1

This Proposal, and Agreement have
been prepared by:

**CITY ENGINEERING DIVISION
CITY OF MADISON
MADISON, DANE COUNTY, WISCONSIN**



Robert F. Phillips, P.E., City Engineer

RFP: jf

SECTION A: ADVERTISEMENT FOR BIDS AND INSTRUCTIONS TO BIDDERS

REQUEST FOR BID FOR PUBLIC WORKS CONSTRUCTION CITY OF MADISON, WISCONSIN

A BEST VALUE CONTRACTING MUNICIPALITY

PROJECT NAME:	RESURFACING 2016 – ASPHALT PAVEMENT PULVERIZING, MILLING & PAVING
CONTRACT NO.:	7616
SBE GOAL	7%
BID BOND	5%
PRE BID MEETING (1:00 P.M.)	1/29/2016
PREQUALIFICATION APPLICATION DUE (1:00 P.M)	1/29/2016
BID SUBMISSION (1:00 P.M.)	2/5/2016
BID OPEN (1:30 P.M.)	2/5/2016
PUBLISHED IN WSJ	1/22/2016 & 1/29/2016

PRE BID MEETING: Representatives of the Affirmative Action Department will be present to discuss the Small Business Enterprise requirements at 1600 Emil Street, Madison Wisconsin.

PREQUALIFICATION APPLICATION: Forms are available on our website, www.cityofmadison.com/business/pw/forms.cfm. If not currently prequalified in the categories listed in Section A, an amendment to your Prequalification will need to be submitted prior to the same due date. Postmark is not applicable.

BIDS TO BE SUBMITTED by hand to 1600 EMIL ST., MADISON, WI 53713 or online at www.bidexpress.com.

THE BID OPENING is at 1600 EMIL ST., MADISON, WI 53713.

STANDARD SPECIFICATIONS

The City of Madison's Standard Specifications for Public Works Construction - 2015 Edition, as supplemented and amended from time to time, forms a part of these contract documents as if attached hereto.

These standard specifications are available on the City of Madison Public Works website, www.cityofmadison.com/Business/PW/specs.cfm.

The Contractor shall review these Specifications prior to preparation of proposals for the work to be done under this contract, with specific attention to Article 102, "BIDDING REQUIREMENTS AND CONDITIONS" and Article 103, "AWARD AND EXECUTION OF THE CONTRACT." For the convenience of the bidder, below are highlights of three subsections of the specifications.

SECTION 102.1: PRE-QUALIFICATION OF BIDDERS

In accordance with Wisconsin State Statutes 66.0901 (2) and (3), all bidders must submit to the Board of Public Works proof of responsibility on forms furnished by the City. The City requires that all bidders be qualified on a biennial basis.

Bidders must present satisfactory evidence that they have been regularly engaged in the type of work specified herein and they are fully prepared with necessary capital, materials, machinery and supervisory

personnel to conduct the work to be contracted for to the satisfaction of the City. All bidders must be pre-qualified by the Board of Public Works for the type of construction on which they are bidding prior to the opening of the bid.

In accordance with Section 39.02(9)(a)l. of the General Ordinances, all bidders shall submit in writing to the Affirmative Action Division Manager of the City of Madison, a Certificate of Compliance or an Affirmative Action Plan at the same time or prior to the submission of the proof of responsibility forms.

The bidder shall be disqualified if the bidder fails to or refuses to, prior to opening of the bid, submit a Certificate of compliance, Affirmative Action Plan or Affirmative Action Data Update, as applicable, as defined by Section 39.02 of the General Ordinances (entitled Affirmative Action) and as required by Section 102.11 of the Standard Specifications.

SECTION 102.4 PROPOSAL

No bid will be accepted that does not contain an adequate or reasonable price for each and every item named in the Schedule of Unit Prices.

A lump sum bid for the work in accordance with the plans and specifications is required. The lump sum bid must be the same as the total amounts bid for the various items and it shall be inserted in the space provided.

All papers bound with or attached to the proposal form are considered a part thereof and must not be detached or altered when the proposal is submitted. The plans, specifications and other documents designated in the proposal form will be considered a part of the proposal whether attached or not.

A proposal submitted by an individual shall be signed by the bidder or by a duly authorized agent. A proposal submitted by a partnership shall be signed by a member/partner or by a duly authorized agent thereof. A proposal submitted by a corporation shall be signed by an authorized officer or duly authorized registered agent of such corporation, and the proposal shall show the name of the State under the laws of which such corporation was chartered. The required signatures shall in all cases appear in the space provided thereof on the proposal.

Each proposal shall be placed, together with the proposal guaranty, in a sealed envelope, so marked as to indicate name of project, the contract number or option to which it applies, and the name and address of the Contractor or submitted electronically through Bid Express (www.bidexpress.com). Proposals will be accepted at the location, the time and the date designated in the advertisement. Proposals received after the time and date designated will be returned to the bidder unopened.

The Bidder shall execute the Disclosure of Ownership form. REFER TO SECTION F.

SECTION 102.5: BID DEPOSIT (PROPOSAL GUARANTY)

All bids, sealed or electronic, must be accompanied with a Bid Bond equal to at least 5% of the bid or a Certificate of Annual/Biennial Bid Bond or certified check, payable to the City Treasurer. Bid deposit of the successful bidders shall be returned within forty-eight (48) hours following execution of the contract and bond as required.

PREVAILING WAGE RATES

Prevailing Wage Rates may be required and are attached in Section J of the contract. See Special Provisions to determine applicability.

Bidders for this Contract(s) must be Pre-Qualified for at least one of the following type(s) of construction denoted by an

Building Demolition

- 101 Asbestos Removal
- 120 House Mover

- 110 Building Demolition

Street, Utility and Site Construction

- 201 Asphalt Paving
- 205 Blasting
- 210 Boring/Pipe Jacking
- 215 Concrete Paving
- 220 Con. Sidewalk/Curb & Gutter/Misc. Flat Work
- 221 Concrete Bases and Other Concrete Work
- 222 Concrete Removal
- 225 Dredging
- 230 Fencing
- 235 Fiber Optic Cable/Conduit Installation
- 240 Grading and Earthwork
- 241 Horizontal Saw Cutting of Sidewalk
- 242 Infrared Seamless Patching
- 245 Landscaping, Maintenance
- 250 Landscaping, Site and Street
- 251 Parking Ramp Maintenance
- 252 Pavement Marking
- 255 Pavement Sealcoating and Crack Sealing
- 260 Petroleum Above/Below Ground Storage Tank Removal/Installation
- 262 Playground Installer
- 265 Retaining Walls, Precast Modular Units

- 270 Retaining Walls, Reinforced Concrete
- 275 Sanitary, Storm Sewer and Water Main Construction
- 276 Sawcutting
- 280 Sewer Lateral Drain Cleaning/Internal TV Insp.
- 285 Sewer Lining
- 290 Sewer Pipe Bursting
- 295 Soil Borings
- 300 Soil Nailing
- 305 Storm & Sanitary Sewer Laterals & Water Svc.
- 310 Street Construction
- 315 Street Lighting
- 318 Tennis Court Resurfacing
- 320 Traffic Signals
- 325 Traffic Signing & Marking
- 332 Tree pruning/removal
- 333 Tree, pesticide treatment of
- 335 Trucking
- 340 Utility Transmission Lines including Natural Gas, Electrical & Communications
- 399 Other Asphalt Milling/Pulverizing

Bridge Construction

- 501 Bridge Construction and/or Repair

Building Construction

- 401 Floor Covering (including carpet, ceramic tile installation, rubber, VCT)
- 402 Building Automation Systems
- 403 Concrete
- 404 Doors and Windows
- 405 Electrical - Power, Lighting & Communications
- 410 Elevator - Lifts
- 412 Fire Suppression
- 413 Furnishings - Furniture and Window Treatments
- 415 General Building Construction, Equal or Less than \$250,000
- 420 General Building Construction, \$250,000 to \$1,500,000
- 425 General Building Construction, Over \$1,500,000
- 428 Glass and/or Glazing
- 429 Hazardous Material Removal
- 430 Heating, Ventilating and Air Conditioning (HVAC)
- 433 Insulation - Thermal
- 435 Masonry/Tuck pointing

- 437 Metals
- 440 Painting and Wallcovering
- 445 Plumbing
- 450 Pump Repair
- 455 Pump Systems
- 460 Roofing and Moisture Protection
- 464 Tower Crane Operator
- 461 Solar Photovoltaic/Hot Water Systems
- 465 Soil/Groundwater Remediation
- 466 Warning Sirens
- 470 Water Supply Elevated Tanks
- 475 Water Supply Wells
- 480 Wood, Plastics & Composites - Structural & Architectural
- 499 Other _____

State of Wisconsin Certifications

- 1 Class 5 Blaster - Blasting Operations and Activities 2500 feet and closer to inhabited buildings for quarries, open pits and road cuts.
- 2 Class 6 Blaster - Blasting Operations and Activities 2500 feet and closer to inhabited buildings for trenches, site excavations, basements, underwater demolition, underground excavations, or structures 15 feet or less in height.
- 3 Class 7 Blaster - Blasting Operations and Activities for structures greater than 15 ' in height, bridges, towers, and any of the objects or purposes listed as "Class 5 Blaster or Class 6 Blaster".
- 4 Petroleum Above/Below Ground Storage Tank Removal and Installation (Attach copies of State Certifications.)
- 5 Hazardous Material Removal (Contractor to be certified for asbestos and lead abatement per the Wisconsin Department of Health Services, Asbestos and Lead Section (A&LS).) See the following link for application: www.dhs.wisconsin.gov/Asbestos/Cert. State of Wisconsin Performance of Asbestos Abatement Certificate must be attached.
- 6 Certification number as a Certified Arborist or Certified Tree Worker as administered by the International Society of Arboriculture
- 7 Pesticide application (Certification for Commercial Applicator For Hire with the certification in the category of turf and landscape (3.0) and possess a current license issued by the DATCP)
- 8 State of Wisconsin Master Plumbers License.

SECTION B: PROPOSAL

Please refer to the
Bid Express Website
at <https://bidexpress.com>
look up contract number
and go to
Section B: Proposal Page

You can access all City of Madison bid solicitations for FREE at www.bidexpress.com

Click on the "Register for Free" button and follow the instructions to register your company and yourself. You will be asked for a payment subscription preference, since you may wish to bid online someday. Simply choose the method to pay on a 'per bid' basis. This requires no payment until / unless you actually bid online. You can also choose the monthly subscription plan at this time. You will, however, be asked to provide payment information. Remember, you can change your preference at anytime. You will then be able to complete your free registration and have full access to the site. Your free access does not require completion of the 'Digital ID' process, so you will have instant access for viewing and downloading. To be prepared in case you ever do wish to bid online, you may wish to establish your digital ID also, since you cannot bid without a Digital ID.

If you have any problems with the free registration process, you can call the bidexpress help team, toll free at 1-888-352-2439 (option 1, option1).

SECTION C: SMALL BUSINESS ENTERPRISE

Instructions to Bidders City of Madison SBE Program Information

2 Small Business Enterprise (SBE) Program Information

2.1 Policy and Goal

The City of Madison reaffirms its policy of nondiscrimination in the conduct of City business by maintaining a procurement process which remains open to all who have the potential and ability to sell goods and services to the City. It is the policy of the City of Madison to allow Small Business Enterprises (SBE) maximum feasible opportunity to participate in City of Madison contracting. The bidder acknowledges that its bid has been submitted in accordance with the SBE program and is for the public's protection and welfare.

Please refer to the "ADVERTISEMENT FOR BIDS" for the goal for the utilization of SBEs on this project. SBEs may participate as subcontractors, vendors and/or suppliers, which provide a commercially useful function. The dollar value for SBE suppliers or 'materials only' vendors shall be discounted to 60% for purposes of meeting SBE goals.

A bidder which achieves or exceeds the SBE goal will be in compliance with the SBE requirements of this project. In the event that the bidder is unable to achieve the SBE goal, the bidder must demonstrate that a good faith effort to do so was made. Failure to either achieve the goal or demonstrate a good faith effort to do so will be grounds for the bidder being deemed a non-responsible contractor ineligible for award of this contract.

A bidder may count towards its attainment of the SBE goal only those expenditures to SBEs that perform a commercially useful function. For purposes of evaluating a bidder's responsiveness to the attainment of the SBE goal, the contract participation by an SBE is based on the percentage of the total base bid proposed by the Contractor. The total base bid price is inclusive of all addenda.

Work performed by an SBE firm in a particular transaction can be counted toward the goal only if it involves a commercially useful function. That is, in light of industry practices and other relevant considerations, does the SBE firm have a necessary and useful role in the transaction, of a kind for which there is a market outside the context of the SBE Program, or is the firm's role a superfluous step added in an attempt to obtain credit towards goals? If, in the judgment of the Affirmative Action Division, the SBE firm will not perform a commercially useful function in the transaction, no credit towards goals will be awarded.

The question of whether a firm is performing a commercially useful function is completely separate from the question of whether the firm is an eligible SBE. A firm is eligible if it meets the definitional criteria and ownership and control requirements, as set forth in the City of Madison's SBE Program.

If the City of Madison determines that the SBE firm is performing a commercially useful function, then the City of Madison must then decide what that function is. If the commercially useful function is that of an SBE vendor / supplier that regularly transacts business with the respective product, then the City of Madison will count 60% of the value of the product supplied toward SBE goals.

To be counted, the SBE vendor / supplier must be engaged in selling the product in question to the public. This is important in distinguishing an SBE vendor / supplier, which has a regular trade with a variety of customers, from a firm which performs supplier-like functions on an ad hoc basis or for only one or two contractors with whom it has a special relationship.

A supplier of bulk goods may qualify as an eligible SBE vendor / supplier if it either maintains an inventory or owns or operates distribution equipment. With respect to the distribution equipment; e.g., a fleet of trucks, the term "operates" is intended to cover a situation in which the supplier leases the equipment on a regular basis for its entire business. It is not intended to cover a situation in which the firm simply provides drivers for trucks owned or leased by another party; e.g., a prime contractor, or leases such a party's trucks on an ad hoc basis for a specific job.

If the commercially useful function being performed is not that of a qualified SBE vendor / supplier, but rather that of delivery of products, obtaining bonding or insurance, procurement of personnel, acting as a broker or manufacturer's representative in the procurement of supplies, facilities, or materials, etc., only the fees or commissions will apply towards the goal.

For example, a business that simply transfers title of a product from manufacturer to ultimate purchaser; e. g., a sales representative who re-invoices a steel product from the steel company to the Contractor, or a firm that puts a product into a container for delivery would not be considered a qualified SBE vendor / supplier. The Contractor would not receive credit based on a percentage of the cost of the product for working with such firms.

Concerning the use of services that help the Contractor obtain needed supplies, personnel, materials or equipment to perform a contract: only the fee received by the service provider will be counted toward the goal. For example, use of a SBE sales representative or distributor for a steel company, if performing a commercially useful function at all, would entitle the Contractor receiving the steel to count only the fee paid to the representative or distributor toward the goal. This provision would also govern fees for professional and other services obtained expressly and solely to perform work relating to a specific contract.

Concerning transportation or delivery services: if an SBE trucking company picks up a product from a manufacturer or a qualified vendor / supplier and delivers the product to the Contractor, the commercially useful function it is performing is not that of a supplier, but simply that of a transporter of goods. Unless the trucking company is itself the manufacturer or a qualified vendor / supplier in the product, credit cannot be given based on a percentage of the cost of the product. Rather, credit would be allowed for the cost of the transportation service.

The City is aware that the rule's language does not explicitly mention every kind of business that may contribute work on this project. In administering these programs, the City would, on a case-by-case basis, determine the appropriate counting formula to apply in a particular situation.

2.2 Contract Compliance

Questions concerning the SBE Program shall be directed to the Contract Compliance Officer of the City of Madison Department of Civil Rights, Affirmative Action Division, 210 Martin Luther King, Jr. Blvd., Room 523, Madison, WI 53703; telephone (608) 266-4910.

2.3 Certification of SBE by City of Madison

The Affirmative Action Division maintains a directory of SBEs which are currently certified as such by the City of Madison. Contact the Contract Compliance Officer as indicated in Section 2.2 to receive a copy of the SBE Directory or you may access the SBE Directory online at www.cityofmadison.com/dcr/aaTBDDir.cfm.

All contractors, subcontractors, vendors and suppliers seeking SBE status must complete and submit the **Targeted Business Certification Application** to the City of Madison Affirmative Action Division by the time and date established for receipt of bids. A copy of the Targeted Business Certification Application is available by contacting the Contract Compliance Officer at the address and telephone indicated in Section 2.2 or you may access the Targeted Business Certification Application online at www.cityofmadison.com/dcr/aaTBDDir.cfm. Submittal of the Targeted Business Certification Application by the time specified does not guarantee that the applicant will be certified as a SBE eligible to be utilized towards meeting the SBE goal for this project.

2.4 Small Business Enterprise Compliance Report

2.4.1 Good Faith Efforts

Bidders shall take all necessary affirmative steps to assure that SBEs are utilized when possible and that the established SBE goal for this project is achieved. A contractor who self performs a portion of the work, and is pre-qualified to perform that category of work, may subcontract that portion of the work, but shall not be required to do so. When a bidder is unable to achieve the established SBE goal, the bidder must demonstrate that a good faith effort to do so was made. Such a good faith effort should include the following:

- 2.4.1.1 Attendance at the pre-bid meeting.
- 2.4.1.2 Using the City of Madison's directory of certified SBEs to identify SBEs from which to solicit bids.
- 2.4.1.3 Assuring that SBEs are solicited whenever they are potential sources.
- 2.4.1.4 Referring prospective SBEs to the City of Madison Affirmative Action Division for certification.
- 2.4.1.5 Dividing total project requirements into smaller tasks and/or quantities, where economically feasible, to permit maximum feasible SBE participation.
- 2.4.1.6 Establishing delivery schedules, where requirements permit, which will encourage participation by SBEs.
- 2.4.1.7 Providing SBEs with specific information regarding the work to be performed.
- 2.4.1.8 Contacting SBEs in advance of the deadline to allow such businesses sufficient time to prepare a bid.
- 2.4.1.9 Utilizing the bid of a qualified and competent SBE when the bid of such a business is deemed reasonable (i.e. 5% above the lowest bidder), although not necessarily low.
- 2.4.1.10 Contacting SBEs which submit a bid, to inquire about the details of the bid and confirm that the scope of the work was interpreted as intended.

2.4.2 Reporting SBE Utilization and Good Faith Efforts

The Small Business Enterprise Compliance Report is to be submitted by the bidder with the bid. This report is due by the specified bid closing time and date. Bids submitted without a completed SBE Compliance Report as outlined below

shall be deemed non-responsible and the bidder ineligible for award of this contract.

2.4.2.1 If the Bidder meets or exceeds the goal established for SBE utilization, the Small Business Enterprise Compliance Report shall consist of the following:

2.4.2.1.1 **Cover Page**, Page C-6; and

2.4.2.1.2 **Summary Sheet**, C-7.

2.4.2.2 If the bidder does not meet the goal established for SBE utilization, the Small Business Enterprise Compliance Report shall consist of the following:

2.4.2.2.1 **Cover Page**, Page C-6;

2.4.2.2.2 **Summary Sheet**, C-7; and

2.4.2.2.3 **SBE Contact Report**, C-8 and C-9. (A separate Contact Report must be completed for each applicable SBE which is not utilized.)

2.5 Appeal Procedure

A bidder which does not achieve the established goal and is found non-responsible for failure to demonstrate a good faith effort to achieve such goal and subsequently denied eligibility for award of contract may appeal that decision to the Small Business Enterprises Appeals Committee. All appeals shall be made in writing, and shall be delivered to and received by the City Engineer no later than 4:30 PM on the third business day following the bidder's receipt of the written notification of ineligibility by the Affirmative Action Division Manager. Postmark not acceptable. The notice of appeal shall state the basis for the appeal of the decision of the Affirmative Action Division Manager. The Appeal shall take place in accordance with Madison General Ordinance 33.54.

2.6 SBE Requirements After Award of the Contract

The successful bidder shall identify SBE subcontractors, suppliers and vendors on the subcontractor list in accordance with the specifications. The Contractor shall submit a detailed explanation of any variances between the listing of SBE subcontractors, vendors and/or suppliers on the subcontractor list and the Contractor's SBE Compliance Report for SBE participation.

No change in SBE subcontractors, vendors and/or suppliers from those SBEs indicated in the SBE Compliance Report will be allowed without prior approval from the Engineer and the Affirmative Action Division. The contractor shall submit in writing to the City of Madison Affirmative Action Division a request to change any SBE citing specific reasons which necessitate such a change. The Affirmative Action Division will use a general test of reasonableness in approving or rejecting the contractor's request for change. If the request is approved, the Contractor will make every effort to utilize another SBE if available.

The City will monitor the project to ensure that the actual percentage commitment to SBE firms is carried out.

2.7 SBE Definition and Eligibility Guidelines

A Small Business Enterprise is a business concern awarded certification by the City of Madison. For the purposes of this program a Small Business Enterprise is defined as:

- A. An independent business operated under a single management. The business may not be a subsidiary of any other business and the stock or ownership may not be held by any individual or any business operating in the same or a similar field. In determining whether an entity qualifies as a SBE, the City shall consider all factors relevant to being an independent business including, but not limited to, the date the business was established, adequacy of its resources for the work in which it proposes to involve itself, the degree to which financial, equipment leasing and other relationships exist with other ineligible firms in the same or similar lines of work. SBE owner(s) shall enjoy the customary incidents of ownership and shall share in the risks and profits commensurate with their enjoyment interests, as demonstrated by an examination of the substance rather than form or arrangements that may be reflected in its ownership documents.
- B. A business that has averaged no more than \$4.0 million in annual gross receipts over the prior three year period and the principal owner(s) do not have a personal net worth in excess of \$1.32 million.

Firm and/or individuals that submit fraudulent documents/testimony may be barred from doing business with the City and/or forfeit existing contracts.

SBE certification is valid for one (1) year unless revoked.

**RESURFACING 2016 – ASPHALT PAVEMENT PULVERIZING, MILLING & PAVING
CONTRACT NO. 7616**

Small Business Enterprise Compliance Report

**This information may be submitted electronically through
Bid Express or submitted with bid in sealed envelope.**

Cover Sheet

Prime Bidder Information

Company: _____

Address: _____

Telephone Number: _____ Fax Number: _____

Contact Person/Title: _____

Prime Bidder Certification

I, _____, _____ of
Name Title

_____ certify that the information
Company

contained in this SBE Compliance Report is true and correct to the best of my knowledge and belief.

Witness' Signature

Bidder's Signature

Date

**RESURFACING 2016 – ASPHALT PAVEMENT PULVERIZING, MILLING & PAVING
CONTRACT NO. 7616**

Small Business Enterprise Compliance Report

Summary Sheet

SBE Subcontractors Who Are NOT Suppliers

Name(s) of SBEs Utilized	Type of Work	% of Total Bid Amount
		%
		%
		%
		%
		%
		%
		%
		%
		%
		%
		%
		%
		%
		%
		%
		%
Subtotal SBE who are NOT suppliers:		_____ %

SBE Subcontractors Who Are Suppliers

Name(s) of SBEs Utilized	Type of Work	% of Total Bid Amount
		%
		%
		%
		%
		%
		%
		%
Subtotal Contractors who are suppliers:	_____ % x 0.6 = _____	_____ % (discounted to 60%)

Total Percentage of SBE Utilization: _____ %.

**RESURFACING 2016 – ASPHALT PAVEMENT PULVERIZING, MILLING & PAVING
CONTRACT NO. 7616**

Small Business Enterprise Compliance Report

SBE Contact Report

Submit separate copy of this form for each SBE which you are not able to utilize towards meeting the SBE goal for this project. Attach separate sheets if necessary.

SBE Information

Company: _____

Address: _____

Telephone Number: _____

Contact Person/Title: _____

1. Outline below all efforts to solicit a bid from the above SBE. Include date, means of contact, who from your company made this contact and the result.

2. Describe the information provided to the aforementioned SBE regarding the scope of work for which he/she was to provide a bid.

Is this the same scope of work on which the subcontractor you intend to utilize based his/her bid?

Yes No

3. Did this SBE submit a bid? Yes No

4. Is the General Contractor pre-qualified to self-perform this category of work?

Yes No

5. If you responded "Yes" to Question 3, please check the items below which apply and provide the requested detail. If you responded "No" to Question 3, please skip ahead to item 6 below.

The SBE listed above is unavailable for work on this project for the following reasons. Provide specific detail for this conclusion.

The SBE listed above is unqualified for work on this project. Provide specific details for this conclusion.

The SBE listed above provided a price that was unreasonable (i.e. more than 5% above the lowest bidder). Provide specific detail for this conclusion including the SBE's price and the price of the subcontractor you intend to utilize.

A contract with the SBE listed above may constitute a breach of the bidder's collective bargaining agreements. Provide specific detail for this conclusion including, but not limited to, correspondence from the SBE indicating it will not sign a project labor agreement and/or correspondence from the applicable trade union indicating a project labor agreement will not be allowed at the time of project bidding.

Other; please specify reason(s) other than listed above which made it impossible for you to utilize this SBE on this project.

6. Describe any other good faith efforts:

SECTION D: SPECIAL PROVISIONS

RESURFACING 2016 – ASPHALT PAVEMENT PULVERIZING, MILLING & PAVING CONTRACT NO. 7616

It is the intent of these Special Provisions to set forth the final contractual intent as to the matter involved and shall prevail over the Standard Specifications and plans whenever in conflict therewith. In order that comparisons between the Special Provisions can be readily made, the numbering system for the Special Provisions is equivalent to that of the Specifications.

Whenever in these Specifications the term “Standard Specifications” appears, it shall be taken to refer to the City of Madison Standard Specifications for Public Works Construction and Supplements thereto.

SECTION 102.9: BIDDER’S UNDERSTANDING

Ban the Box: The City’s Ban the Box ordinance will apply to all contracts executed after January 1, 2016. The requirements are found in Section 39.08 of the Madison General Ordinances, “Ban the Box – Arrest and Criminal Background Checks” and in Section H of this bid solicitation. This ordinance requires contractors to remove questions about criminal and arrest history from job applications and refrain from conducting background checks until a conditional offer of employment is made. This ordinance applies to all prime contractors on contracts entered into on or after January 1, 2016, and all subcontractors who are required to meet prequalification requirements under MGO 33.07(7)(l), MGO as of the first time they seek or renew pre-qualification status on or after January 1, 2016. Prime contractors must agree to comply for the duration of their contract. The City will monitor compliance of subcontractors through the pre-qualification process. Bidders shall review the contract language prior to bidding – see Section H of this bid solicitation for the contract language and requirements.

Tax Exempt Status: Effective with all contracts executed after January 1, 2016, the sales price from the sale, storage, use or other consumption of tangible personal property that is used in conjunction with a public works improvement for a tax exempt entity (including the City of Madison), is exempt from State sales tax. Said property must become a component of the project owned by the tax exempt entity and includes: any building; shelter; parking lot; parking garage; athletic field; storm sewer; water supply system; or sewerage and waste water treatment facility, but does not include a highway, street or road.

The contractor shall ensure that the exemption for sales and use tax available under Wis. Stat. Sec. 77.54(9m) applies where available. The contractor shall provide all necessary documentation as required by the State of Wisconsin and the City of Madison to comply with this exemption.

SECTION 102.10: PREVAILING WAGE

For this project, payment of prevailing wages (white sheet) shall be required unless the box indicating prevailing wages are not required is checked below.

Prevailing wages shall not be required when this box is checked.

If prevailing wages (white sheets) are required, the wages and benefits paid on the contract shall not be less than those specified in the Prevailing Wage Determination included with these contract documents for the following types of work:

- Building or Heavy Construction
- Sewer, Water, or Tunnel Construction
- Local Street or Miscellaneous Paving Construction
- Residential or Agricultural Construction

When multiple boxes are checked, worker’s wages may vary according to the type and area of work performed. It is the responsibility of the Contractor to determine and apply the appropriate wage rate for the specific work assigned.

SECTION 102.12 BEST VALUE CONTRACTING

This Contract shall be considered a Best Value Contract if the Contractor's bid is equal to or greater than \$56,500 for a single trade contract; or equal to or greater than \$277,000 for a multi-trade contract pursuant to MGO 33.07(7).

SECTION 104 SCOPE OF WORK

This contract includes pulverizing, milling and paving various streets that are included with the resurfacing program.

This contractor shall be required to coordinate with the other contractors performing work on the resurfacing program contracts.

There are ten (10) new subdivision locations that require surface paving. All work required prior to paving is included in this contract. This work includes wedge cut grinding butt joints and around SASs, tack, and raising water boxes to grade. Raising water boxes to grade shall be included with paving. If, however, excavation is required to adjust the water valve box, the contractor shall be paid for this work under Bid Item 40367.

SECTION 105.6 CONTRACTORS RESPONSIBILITY FOR WORK

The Contractor shall have at all times during the progress of construction one Superintendent as the agent for the Contractor on this work, who is thoroughly understanding of all aspects of the Resurfacing Program and shall receive instructions from the Engineer. The contractor shall verify that all valve castings operate and SAS and utility castings are in place and sealed before acceptance of the pulverized and shaped or milled street. The contractor shall repair as required by the Engineer.

SECTION 105.12 COOPERATION OF THE CONTRACTOR

The City of Madison has been given to understand that the following work will be undertaken by others in approximately the same time frame and the same area as the proposed project. It shall be the Contractor's responsibility to verify this information and any subsequent changes in the scheduling of the work by others and to make corrections in his/her construction timetable as required. The Contractor shall coordinate the work under this contract with the work by others stated below.

The City of Madison Engineering Division will be awarding a contract for curb & gutter replacement and casting adjustment (contract 7615) in conjunction with this contract.

Contractor shall install pavement markings, within two (2) working days of surface paving, as included in this contract on the following streets:

GRAND CANYON DR WESTFIELD RD TREE LN

Traffic Engineering shall install pavement markings on the remaining streets as needed.

Traffic Engineering crews will be replacing or adding traffic signal loops after the pulverizing or milling and before the paving on the following streets with signal loops:

GRAND CANYON DR WESTFIELD RD TREE LN

Streets may be deleted or added to the above list. The contractor shall coordinate installation of any loop detectors and conduit with Traffic Engineering. The Contractor shall notify City Traffic Engineering 48 hours, (Bill Gilbertson 266-4767), prior to final paving.

Cost to repair damage to traffic signal loops that occur after their installation due to Contractor negligence, and cost for extra work to install the traffic signal loops in newly paved streets due to improper notice to the Traffic Engineering Division, will be deducted from the contract.

SECTION 105.13 ORDER OF COMPLETION

Prior to beginning operations under this contract, Contractors involved in the Resurfacing Program shall meet collectively with the Engineer, at the pre-construction meeting, to establish a tentative list in what street order they will proceed. The Engineer shall have final approval regarding the tentative list.

The Contractor shall proceed on this contract so as not to cause delays to the contracts as noted in section 105.12. Delay costs in accordance with section 109.9 “**LIQUIDATED DAMAGES**” of the Standard Specification shall be assessed for each day that the contractors on the above listed contracts are delayed.

SECTION 106.1 SOURCE OF SUPPLY AND QUALITY

No work shall begin on this contract until such time that asphalt mix design(s) are approved by the City of Madison.

SECTION 107.1 PUBLIC CONVENIENCE AND SAFETY

There is a Fire Station on Grand Canyon Dr. The contractor shall maintain access at all times. The contractor shall coordinate work at times with the Fire Station. The contractor shall inform the Fire Station of activities on a daily basis.

Access to businesses shall be maintained at all times.

The contractor shall not work on streets abutting school property while school is in session unless approved by the Engineer. Memorial High School and Jefferson Middle School are at the limit of Tree Lane.

SECTION 107.6 DUSTPROOFING

The Contractor shall take all necessary steps to control dust arising from operations connected with this contract. When ordered by the Engineer, the Contractor shall dust proof the construction area by using power sweepers and water. Dustproofing shall be incidental with operations connected with this contract.

SECTION 107.7 MAINTENANCE OF TRAFFIC

There is a Fire Station on Grand Canyon Dr. The contractor shall maintain access to the Fire Station at all times.

The Contractor shall be responsible for installing and maintaining traffic control in accordance with the approved Traffic Control Plan and as directed by the City Traffic Engineer. The traffic control plan may need to be altered as conditions change in the field or as unexpected conditions occur. This may include relocating existing traffic control or providing additional traffic control. The Contractor shall install and maintain any necessary modifications or additions to the traffic control, as directed by the City Traffic Engineer, at no cost to the City.

All signing and barricading shall conform to the Federal Highways Administrations “Manual on Uniform Traffic Control Devices” (MUTCD).

No construction equipment or materials shall be stored in the peak hour restriction roadway or street right-of-way that is open to traffic during non-working hours.

The Traffic Control Plan shall be submitted to the office of the City Traffic Engineer, at 215 Martin Luther King, Jr. Blvd, Suite 100, Madison, WI 53703, a minimum of five (5) working days prior to the pre-construction meeting. The Traffic Control Plans shall address all requirements of this section of the Special Provisions. The successful bidder shall work with the City Traffic Engineering Division to develop approved Traffic Control Plans. The Contractor shall not start work on this project until the Traffic Engineering Division has approved a traffic control plan and traffic control devices have been installed, in accordance with the approved plan. Failure of the Contractor to obtain approval of a Traffic Control Plan, as specified above, may prevent the Contractor from starting work and shall be considered a delay of the project, caused by the Contractor.

The Contractor shall submit acceptable Traffic Control Plans for the following streets to be resurfaced:

GRAND CANYON DR WESTFIELD RD TREE LN

Contact Thomas Mohr, Traffic Engineering Division, 267-8725, with any questions concerning these traffic control specifications.

Refer to section 403.1 of the City of Madison Standard Specifications for Traffic Control.

Traffic Control and Mobilization shall be paid per the following street groupings:

GROUP A WESTFIELD RD TREE LN	GROUP D TRAFALGER PL RUBY CT PICCADILLY DR ANDREW WAY	GROUP F SUBDIVISIONS (10)
GROUP B JUPITER DR		
GROUP C GRAND CANYON DR	GROUP E GLADSTONE DR	

If streets are added or deleted to Group A through Group F, compensation shall be increased or decreased for the change in Traffic Control.

The unit price bid for items 10701R, 10701S or 10701T shall be used for additions and deletions to the groups above or if additional streets are added.

The unit price bid for item 10911R shall be used for additions and deletions to the groups above or if additional streets are added.

BID ITEM 10701R – TRAFFIC CONTROL – LOCAL STREET (undistributed)

DESCRIPTION

This bid item shall be used for streets added/deleted to the list of streets contained in this contract. Local streets are those streets defined as “LOCAL” on the City of Madison Highway and Street Functional Classification Map. Work under this item shall include providing traffic control in accordance with Section 403.1 of the City of Madison Standard Specifications and the Federal Highways Administration “Manual on Uniform Traffic Control Devices” (MUTCD).

METHOD OF MEASUREMENT

Traffic control – Local street shall be measured by the unit of Each per street added/deleted to the contract.

BASIS OF PAYMENT

Traffic Control – Local Street measured as provided above shall be paid for at the contract unit price per Each which shall be full compensation for all work, materials, labor and incidentals required to complete the work as set forth in the description.

BID ITEM 10701S– TRAFFIC CONTROL – MAJOR STREET, TWO LANES (undistributed)

DESCRIPTION

This bid item shall be used for streets added/deleted to the list of streets contained in this contract. Major streets, two lanes are defined on the City of Madison Highway and Street Functional Classification Map. Work under this item shall include providing traffic control in accordance with Section 403.1 of the City of Madison Standard Specifications and the Federal Highways Administration “Manual on Uniform Traffic Control Devices” (MUTCD).

METHOD OF MEASUREMENT

Traffic control – Major Street, two lanes shall be measured by the unit of Each per street added/deleted to the contract.

BASIS OF PAYMENT

Traffic Control – Major Street, two lanes measured as provided above shall be paid for at the contract unit price per Each which shall be full compensation for all work, materials, labor and incidentals required to complete the work as set forth in the description.

BID ITEM 10701T– TRAFFIC CONTROL – MAJOR STREET, MORE THAN TWO LANES (undistributed)

DESCRIPTION

This bid item shall be used for streets added/deleted to the list of streets contained in this contract. Major streets, more than two lanes are defined on the City of Madison Highway and Street Functional Classification Map. Work under this item shall include providing traffic control in accordance with Section 403.1 of the City of Madison Standard Specifications and the Federal Highways Administration “Manual on Uniform Traffic Control Devices” (MUTCD).

METHOD OF MEASUREMENT

Traffic control – Major Street, more than two lanes shall be measured by the unit of Each per street added/deleted to the contract.

BASIS OF PAYMENT

Traffic Control – Major Street, more than two lanes measured as provided above shall be paid for at the contract unit price per Each which shall be full compensation for all work, materials, labor and incidentals required to complete the work as set forth in the description.

PEAK HOUR RESTRICTIONS

The Contractor and any subcontractor for the Street Resurfacing Program shall be required to adhere to peak hour traffic restrictions between the hours of 7:00 a.m. to 8:30 a.m. and 4:00 p.m. to 5:30 p.m. on the below listed streets. No work shall be done between these hours.

GRAND CANYON DR WESTFIELD RD (TREE LN – MINERAL POINT RD) TREE LN

SECTION 109.2 PROSECUTION OF THE WORK

The Contractor shall begin work on this project on or before **MAY 4, 2016**. Work shall begin only after the start work letter is received. If it is desirable to begin work before the above mentioned date, the Contractor shall establish a mutually acceptable date with the City Engineer (contact the Construction Engineer at 266-9091). The work called for by this contract shall be completed in **FIFTY (50) WORK DAYS**. The time of completion will be computed in accordance with Section 109.7 of the Specifications starting with the latest start date shown or the actual date work begins whichever is sooner.

SECTION 109.5 METHODS AND EQUIPMENT

The Contractor shall inspect and certify, in writing, that all sewer access points are in place, sealed and free of debris prior to leaving each site. If there is any debris in the sewer access points that the Contractor feels is not their responsibility they shall promptly bring it to the attention of the Project Engineer before beginning work. The paving contractor shall verify operation of all valve castings within 24 hours of placement of the lower layer of asphalt. Any repairs required to the new pavement shall be by infrared method or approved by Engineer.

ARTICLE 402 - ASPHALT CONSTRUCTION

402.1 Materials For Asphalt Construction

The City of Madison is requiring an asphalt mix for the E-0.3 pavement with a higher asphalt material content than a typical E-0.3 mix design with air voids of 4.0%. The mix design shall have a target of 3.5% air voids for the E-0.3 mix and a range of 2.7% - 4.3%. This shall be accomplished by increasing the asphalt material to the mix.

403.4 Undercut
 403.4(a) Description

If base problems are encountered, undercut may be required. Excess pulverized material may be used for backfilling the undercut areas, placed in 6" lifts and compacted.

Where directed by the Engineer, crusher run (Breaker) shall be used for backfilling undercut areas placed in six (6) inch lifts and compacted. Placement of crusher run shall be paid under **BID ITEM 20219 - BREAKER RUN.**

403.4(b) Method of Measurement

Undercut shall be measured by cubic yards in its original position, computed by the method of average end areas.

403.4(c) Basis of Payment

The cubic yard volume for undercut, measured as provided above, shall be paid for at the contract unit price per cubic yard, which price shall be full compensation as provided above and in accordance with Article 201 Excavation Cut of the Standard Specifications.

RESURFACING 2016 – PAVEMENT PULVERIZING & PAVING (Contract 7616)

STREET	LIMIT	LIMIT
<u>PULVERIZED STREETS</u>		
WESTFIELD RD	MILLSTONE RD	MINERAL POINT RD
TREE LN	S GAMMON RD	S WESTFIELD RD
JUPITER DR	HALLEY WAY	NORTH STAR DR
GLADSTONE DR	MUIR FIELD RD	SCENIC RIDGE DR
TRAFALGER PL	KURT DR	E END
RUBY CT	TRAFALGER PL	S END
PICCADILLY DR	KURT DR	ANDREW WAY
ANDREW WAY	MILWAUKEE ST	PICCADILLY DR
<u>MILLED STREETS</u>		
GRAND CANYON DR	MINERAL POINT RD	NORMANDY LN

2016 RESURFACING - SUBDIVISIONS ESTIMATE

SUBDIVISION NAME	STREET	LIMITS		MIX/ GRADATION	SURFACE PVMT (IN)	SURFAC E AREA (SY)	WEDGE CUT GRINDING AREAS (SY)	SURFACE			TACK COAT (GAL)	WATER VALVES	
		FROM	TO					E - 0.3 (TON)	E - 1 (TON)	E - 3 (TON)		ADJUST (EA)	REPLAC E (EA)
SUGAR MAPLE PHASE 1	Cherry Blossom	South of Lost Pine Trail	North of Wild Prairie Trail	E-1, 12.5mm	2"	2371	25	0	285	0	119	3	0
PROJECT # 53B2317	Lost Pine Trail	Sugar Maple Lane	East of Cherry Blossom Drive	E-1, 12.5mm	2"	3632	50	0	436	0	182	7	0
CONTRACT # 2317	Wild Prairie Trail	Cherry Blossom Drive	East	E-1, 12.5mm	2"	1779	48	0	213	0	89	7	0
SUBDIVISION TOTAL						7782	123	0	934	0	389	17	0
WOLFE ADDITION TO HAWK'S CREEK	Trevor Way	Flagstone Drive	South End	E-0.3, 12.5mm	1.75"	1845	58	194	0	0	92	3	0
PROJECT # 53W1552, CONTRACT # 7053													
SUBDIVISION TOTAL						1845	58	194	0	0	92	3	0
GRANDVIEW COMMONS PHASE 1	Milky Way	Milwaukee Street	South of Ragan Street	E-0.3, 12.5mm	1.75"	3153	61	331	0	0	158	8	0
PROJECT # 53B2394	Alton Drive	Driscoll Drive	Caldera Street	E-0.3, 12.5mm	1.75"	1739	25	183	0	0	87	2	0
CONTRACT # 2394	Driscoll Drive	Milky Way	East of Alton Drive	E-0.3, 12.5mm	1.75"	1333	25	140	0	0	67	6	0
	Jackson Quarry Lane	West of Milky Way	Milky Way	E-0.3, 12.5mm	1.75"	2233	25	234	0	0	112	2	0
	Ragan Street	Milky Way	Alton Drive	E-0.3, 12.5mm	1.75"	1496	25	157	0	0	75	0	0
SUBDIVISION TOTAL						9953	161	1045	0	0	498	18	0
GRANDVIEW COMMONS PHASE 19	Galileo Drive	South of Venus Way	North of Venus Way	E-0.3, 12.5mm	1.75"	949	28	100	0	0	47	2	0
PROJECT # 53B2352, CONTRACT # 2352	Venus Way	Galileo Drive	East	E-0.3, 12.5mm	1.75"	925	24	97	0	0	46	1	0
SUBDIVISION TOTAL						1874	52	197	0	0	94	3	0
GRANDVIEW COMMONS PHASE 20	Aries Way	West of North Star	Galileo Drive	E-0.3, 12.5mm	1.75"	1986	12	209	0	0	99	1	0
PROJECT # 53B2381	Pluto Street	Aries Way	South of Aries Way	E-0.3, 12.5mm	1.75"	378	12	40	0	0	19	1	0
CONTRACT # 2381	Galileo Drive	North of Aries Way	North of Venus Way	E-0.3, 12.5mm	1.75"	1294	24	136	0	0	65	2	0
	North Star Drive	Dominion Drive	North of Aries Way	E-1, 12.5mm	1.75"	3496	73	0	367	0	175	3	0
SUBDIVISION TOTAL						7154	122	384	367	0	358	7	0
HAWKS VALLEY PHASE 1	Tiercel Drive	West of Raptor Drive	Swainson Drive	E-0.3, 12.5mm	1.75"	1373	0	144	0	0	69	2	0
PROJECT # 53B2271	Ashworth Drive	Swainson Drive	Woods Rd	E-0.3, 12.5mm	1.75"	1293	10	136	0	0	65	1	0
CONTRACT # 2271	Swainson Drive	Tiercel Drive	Ashworth Drive	E-0.3, 12.5mm	1.75"	1272	0	134	0	0	64	5	0
MUNIS # 10082	Raptor Drive	Mid Town Road	South of Tiercel Drive	E-1, 12.5mm	2"	1000	11	0	120	0	50	4	1
SUBDIVISION TOTAL						4938	21	413	120	0	247	12	1
BIRCHWOOD POINT PHASE 3	Rustling Birch Road			E-0.3, 12.5mm	1.75"	331	12	35	0	0	17	1	0
PROJECT # 10505	Meandering Way	Blooming Leaf Lane	East of Sugar Maple Lane	E-0.3, 12.5mm	1.75"	1721	61	181	0	0	86	2	0
CONTRACT # 2414	Arbor Mist Pass	West of Blue Moon Drive	East of Blue Moon Drive	E-0.3, 12.5mm	1.75"	893	12	94	0	0	45	3	0
	Sugar Maple Lane	Rustling Birch Road	North of Arbor Mist Pass	E-3, 12.5mm	1.75"	3800	37	0	0	399	190	2	0
SUBDIVISION TOTAL						6745	122	309	0	399	337	8	0
CROSS OAK DRIVE, FORTUNATE PLACE	Silicon Prairie Parkway			E-1, 12.5mm	1.75"	1443	12	0	152	0	72	4	0
PROJECT # 53W1726	Cross Oak Drive	Silicon Prairie Parkway	Fortunate Place	E-1, 12.5mm	1.75"	1660	35	0	174	0	83	9	0
CONTRACT # 7224	Fortunate Place	Cross Oak Drive	(Carlson Curb?)	E-1, 12.5mm	1.75"	2280	37	0	239	0	114	6	0
SUBDIVISION TOTAL						5383	84	0	565	0	269	19	0
MCALLEN 120 BUSINESS PARK PHASE 2	Meier Road	Femrite Drive	North	E-3, 12.5mm	2"	3200	409	0	0	384	160	5	0
PROJ# 53B2441, CONT# 2441, MUNIS# 11102													
SUBDIVISION TOTAL						3200	409	0	0	384	160	5	0
TRADEWINDS PARKWAY ASSESSMENT	Tradewinds Parkway	West of Jadon Drive	Agriculture Drive	E-3, 12.5mm	1.75"	6825	99	0	0	717	341	18	0
PROJECT # 53W0598, CONTRACT # 6186	Jadon Drive	Tradewinds Parkway	South	E-3, 12.5mm	1.75"	1371	95	0	0	144	69	2	0
SUBDIVISION TOTAL						8196	194	0	0	861	410	20	0
GRAND TOTAL =						57070	1346	2542	1986	1644	2853	112	1

RESURFACING 2016

STREET NAME: RUBY COURT

LIMITS: TRAFALGER PL TO SOUTH END

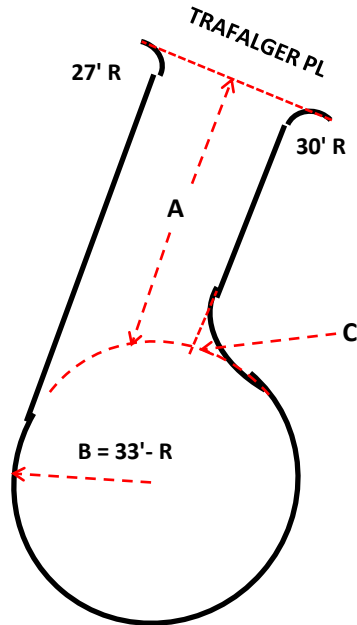
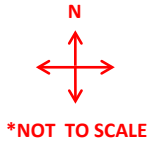

AREA (SY)

$A = 120 \times 28 = 373.3$
 $B = \pi r^2 = 3.14 \times 33 \times 33 = 380.1$
 $C = .5(36 \times 16) = 32$
 $1-30' - R = 24.5$
 $1-27' - R = 20$
TOTAL = 829.9

ITEMS

TACK COAT		GAL
HMA LOWER LAYER		TON
HMA UPPER LAYER	12.5MM E-0.3 / 3" P.G.(58-28)	150.00 TON
ESTIMATED UNDERCUT		125.00 CY
BASE PATCH GRINDING METHOD 3	ESTIMATED	SY
RAMPING SAS		SY
WEDGE CUT GRINDING CONCRETE		SY
FULL WIDTH GRINDING		SY
PULVERIZE		829.90 SY

RESURFACING 2016

STREET NAME: TRAFALGER PLACE
LIMITS: KURT DR TO EAST END

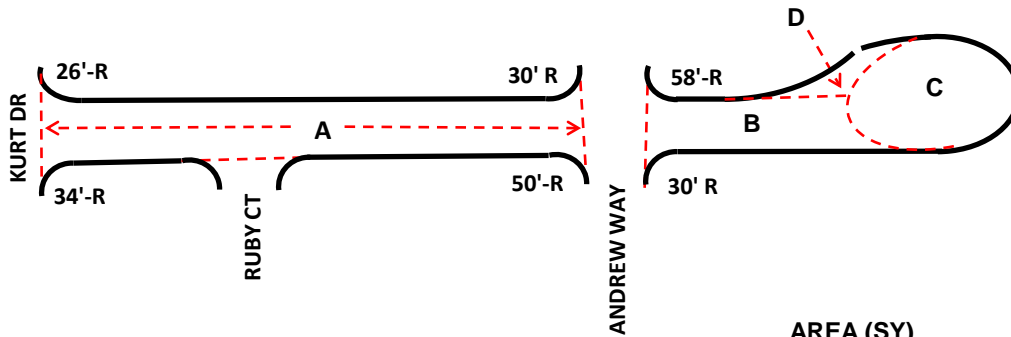
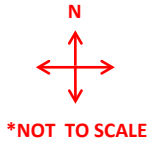

AREA (SY)

$$A = 710 \times 28 = 2208.9$$

$$B = 190 \times 28 = 591.1$$

$$C = \pi r^2 = 3.14 \times 44 \times 44 = 675.8$$

$$D = .5(50 \times 47) = 130.6$$

$$2-30' - R = 49$$

$$1-50' - R = 65$$

$$1-58' - R = 86$$

$$1-26' - R = 18.7$$

$$1-34' - R = 31$$

TOTAL = 3856.1

ITEMS

TACK COAT		GAL
HMA LOWER LAYER		TON
HMA UPPER LAYER	12.5MM E-0.3 / 3" P.G. (58-28)	694.00 TON
ESTIMATED UNDERCUT		580.00 CY
BASE PATCH GRINDING METHOD 3	ESTIMATED	SY
RAMPING SAS		SY
WEDGE CUT GRINDING CONCRETE		SY
FULL WIDTH GRINDING		SY
PULVERIZE		3,856.00 SY

RESURFACING 2016

STREET NAME: PICCADILLY DR
LIMITS: KURT DR TO ANDREW WAY



*NOT TO SCALE

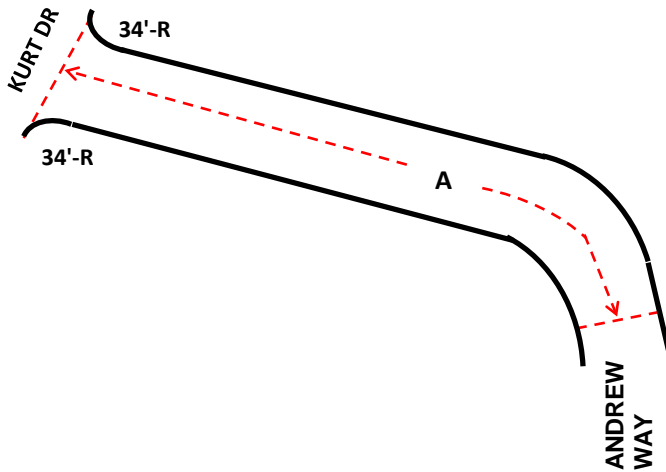

AREA (SY)

$A = 770 \times 28 = 2395.6$

$2 \times 34' - R = 62$

TOTAL = 2457.6

ITEMS

TACK COAT		GAL
HMA LOWER LAYER		TON
HMA UPPER LAYER	12.5MM E-0.3 / 3" P.G. (58-28)	443.00 TON
ESTIMATED UNDERCUT		369.00 CY
BASE PATCH GRINDING METHOD 3	ESTIMATED	SY
RAMPING SAS		SY
WEDGE CUT GRINDING CONCRETE		SY
FULL WIDTH GRINDING		SY
PULVERIZE		2,458.00 SY

RESURFACING 2016

STREET NAME: ANDREW WAY

LIMITS: MILWAUKEE ST TO PICCADILLY DR

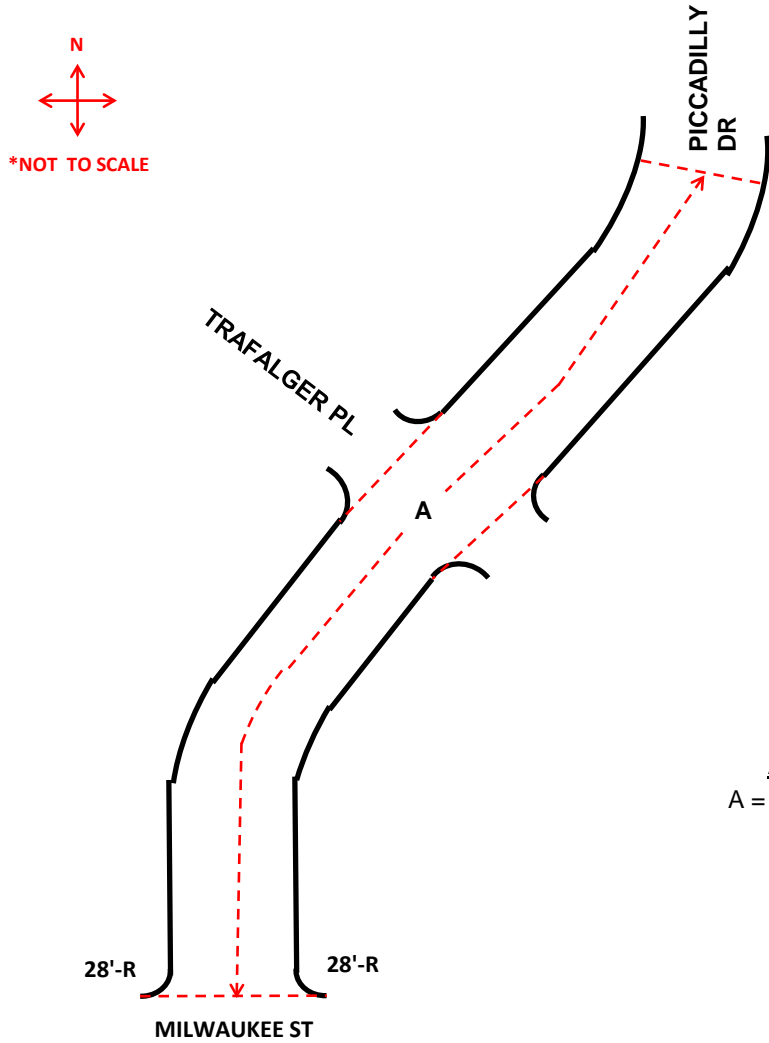

AREA (SY)
 $A = 590 \times 28 = 1835.6$
 $2 \times 28' \times R = 43$
TOTAL = 1878.6

ITEMS

TACK COAT		GAL
HMA LOWER LAYER		TON
HMA UPPER LAYER	12.5MM E-0.3 / 3" P.G. (58-28)	339.00 TON
ESTIMATED UNDERCUT		282.00 CY
BASE PATCH GRINDING METHOD 3	ESTIMATED	SY
RAMPING SAS		SY
WEDGE CUT GRINDING CONCRETE		SY
FULL WIDTH GRINDING		SY
PULVERIZE		1,879.00 SY

RESURFACING 2016

STREET NAME: JUPITER DRIVE

LIMITS: HALLEY WAY TO N. STAR DRIVE

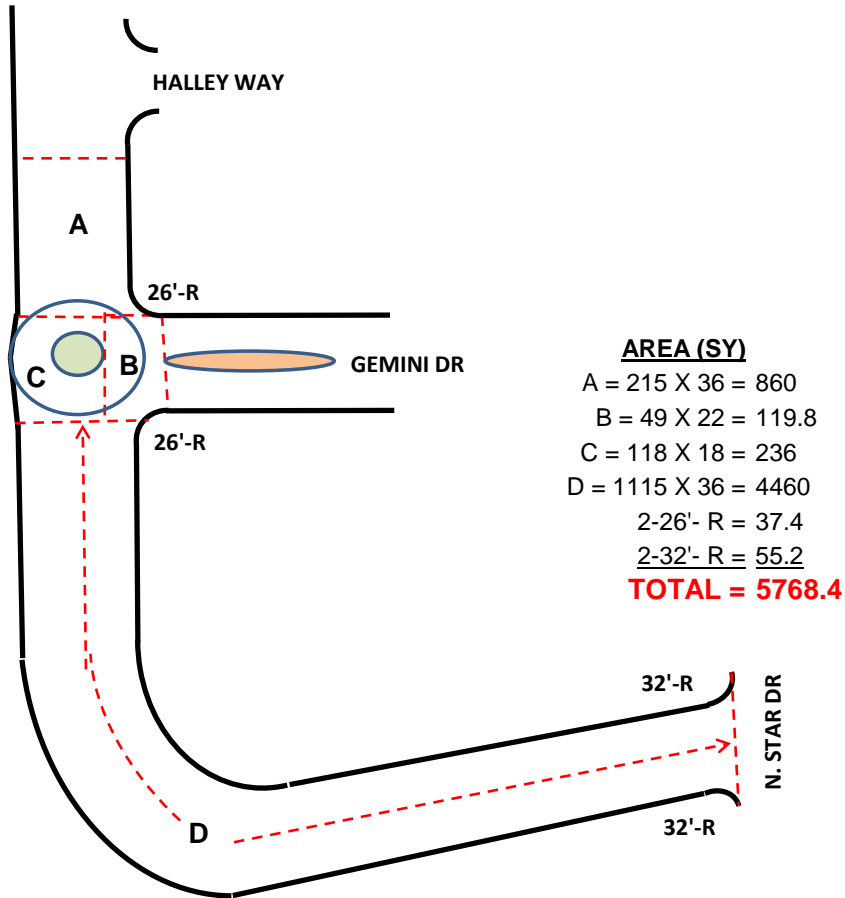

ITEMS

TACK COAT			GAL
HMA LOWER LAYER			TON
HMA UPPER LAYER	12.5MM E-0.3 / 3" P.G. (58-28)	1,039.00	TON
ESTIMATED UNDERCUT		866.00	CY
BASE PATCH GRINDING METHOD 3	ESTIMATED		SY
RAMPING SAS			SY
WEDGE CUT GRINDING CONCRETE			SY
FULL WIDTH GRINDING			SY
PULVERIZE		5,769.00	SY

RESURFACING 2016

STREET NAME: GLADSTONE DRIVE

LIMITS: SCENIC RIDGE DR TO MUIR FIELD RD

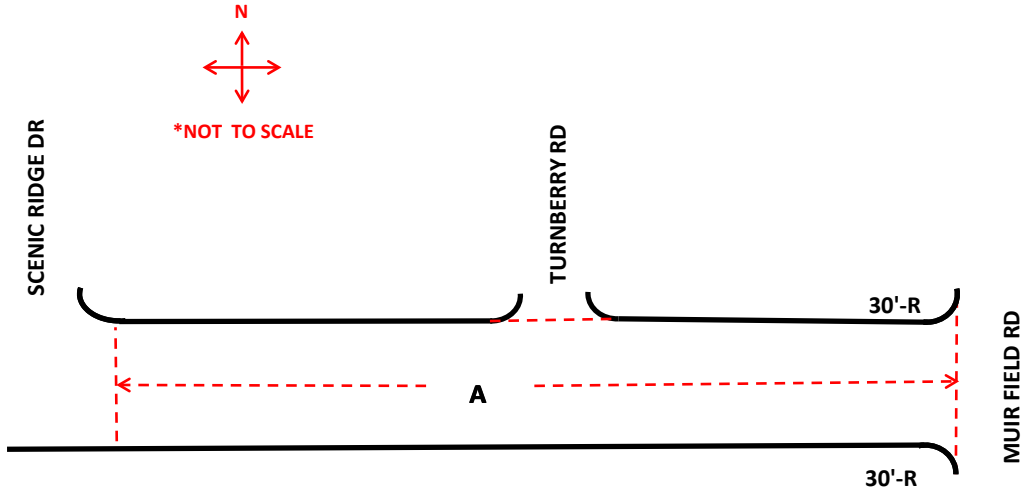

AREA (SY)

$A = 880 \times 28 = 2737.8$

$2 \times 30' - R = 49$

TOTAL = 2786.8

ITEMS

TACK COAT		GAL
HMA LOWER LAYER		TON
HMA UPPER LAYER	12.5MM E-0.3 / 3" P.G. (58-28)	502.00 TON
ESTIMATED UNDERCUT		418.00 CY
BASE PATCH GRINDING METHOD 3	ESTIMATED	SY
RAMPING SAS		SY
WEDGE CUT GRINDING CONCRETE		SY
FULL WIDTH GRINDING		SY
PULVERIZE		2,787.00 SY

RESURFACING 2016

STREET NAME: S. WESTFIELD RD

LIMITS: MILLSTONE RD TO MINERAL PT RD

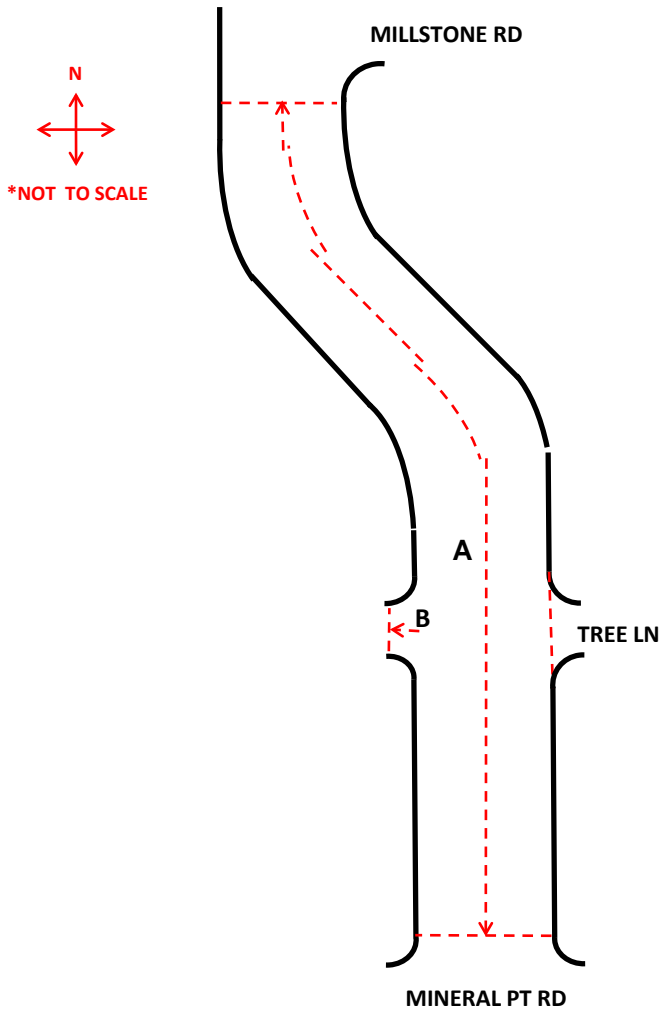

AREA (SY)
 $A = 2405 \times 40 = 10688.9$
 $B = 73 \times 5 = 40.6$
TOTAL = 10729.5

ITEMS

TACK COAT		537.00	GAL
HMA LOWER LAYER	19MM E-3 / 2.5" P.G. (58-28)	1,610.00	TON
HMA UPPER LAYER	12.5MM E-3 / 2" P.G. (58-28)	1,288.00	TON
ESTIMATED UNDERCUT		1,610.00	CY
BASE PATCH GRINDING METHOD 3	ESTIMATED		SY
RAMPING SAS			SY
WEDGE CUT GRINDING CONCRETE			SY
FULL WIDTH GRINDING			SY
PULVERIZE		10,730.00	SY

RESURFACING 2016

STREET NAME: TREE LANE

LIMITS: S. WESTFIELD RD TO S. GAMMON RD



*NOT TO SCALE

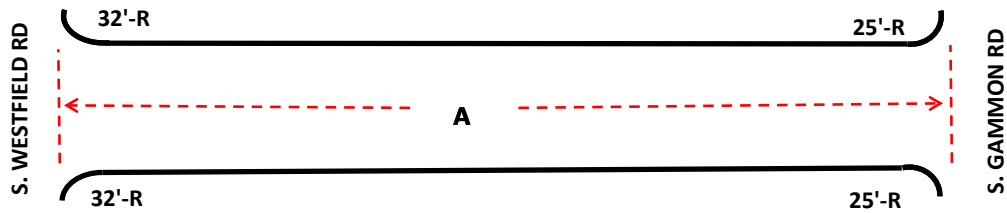

AREA (SY)

$A = 1510 \times 36 = 6040$

$2 \times 25' \text{ R} = 34.8$

$2 \times 32' \text{ R} = 55.2$

TOTAL = 6130

ITEMS

TACK COAT		307.00	GAL
HMA LOWER LAYER	19MM E-3 / 2.5" P.G. (58-28)	920.00	TON
HMA UPPER LAYER	12.5MM E-3 / 2" P.G. (58-28)	736.00	TON
ESTIMATED UNDERCUT		920.00	CY
BASE PATCH GRINDING METHOD 3	ESTIMATED		SY
RAMPING SAS			SY
WEDGE CUT GRINDING CONCRETE			SY
FULL WIDTH GRINDING			SY
PULVERIZE		6,130.00	SY

RESURFACING 2016

STREET NAME: GRAND CANYON DR
LIMITS: NORMANDY LN TO MINERAL PT RD

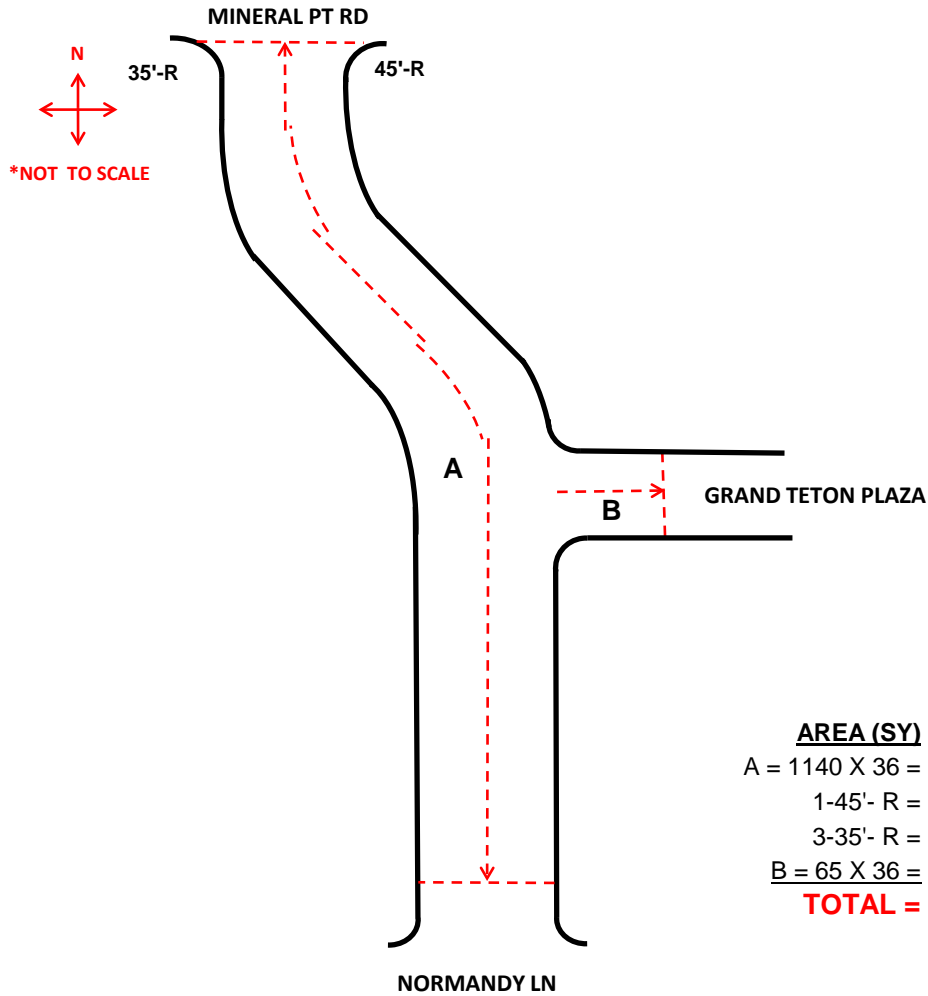

AREA (SY)
A = 1140 X 36 = 4560
1-45'- R = 52.8
3-35'- R = 98.1
B = 65 X 36 = 260.0
TOTAL = 4970.9

ITEMS

TACK COAT		250.00	GAL
HMA LOWER LAYER			TON
HMA UPPER LAYER	12.5MM E-3 / 3" P.G. (58-28)	895.00	TON
ESTIMATED UNDERCUT			CY
BASE PATCH GRINDING METHOD 2	ESTIMATED	1,000.00	SY
BASE PATCH GRINDING METHOD 3	ESTIMATED	500.00	SY
BASE PATCH GRINDING METHOD 5	ESTIMATED	500.00	SY
FULL WIDTH GRINDING		4,971.00	SY
PULVERIZE			SY



PLOT SCALE:

PLOT NAME:

REV. DATE:

ORIGINATOR: CITY OF MADISON, TRAFFIC ENG. DIV.

MINERAL POINT RD

N WESTFIELD RD

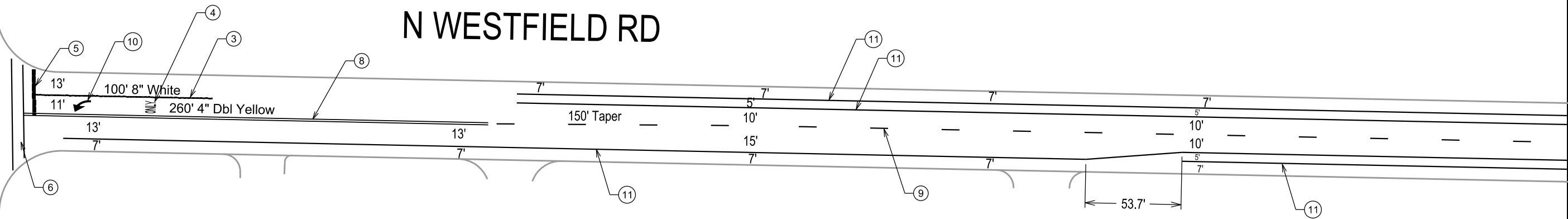

Callout	Bid Item	Description
1	60802	Pavement Marking Epoxy, 6-Inch White Skips, (10' Line, 30' Gap)
2	60800	Pavement Marking Epoxy, 4-Inch, Solid White
3	60803	Pavement Marking Epoxy, 8-Inch Solid White
4	60834	Pavement Marking Epoxy, Word, "ONLY"
5	60818	Pavement Marking Epoxy, 24-Inch White, Stop Line
6	60812	Pavement Marking Epoxy, 6-Inch White, Crosswalk
7	60823	Pavement Marking Epoxy, Symbol, Bike Lane
8	60801	Pavement Marking Epoxy, 4-Inch Double Yellow
9	60802	Pavement Marking Epoxy, 6-Inch Yellow Skips (10' Line, 30' Gap)
10	60829	Pavement Marking Epoxy, Symbol, Left Arrow
11	60802	Pavement Marking Epoxy, 6-Inch Solid White
12	60802	Pavement Marking Epoxy, 6-Inch White Skips, (2' Line, 6' Gap)

Contact Tom Mohr, 608-267-8725 with questions

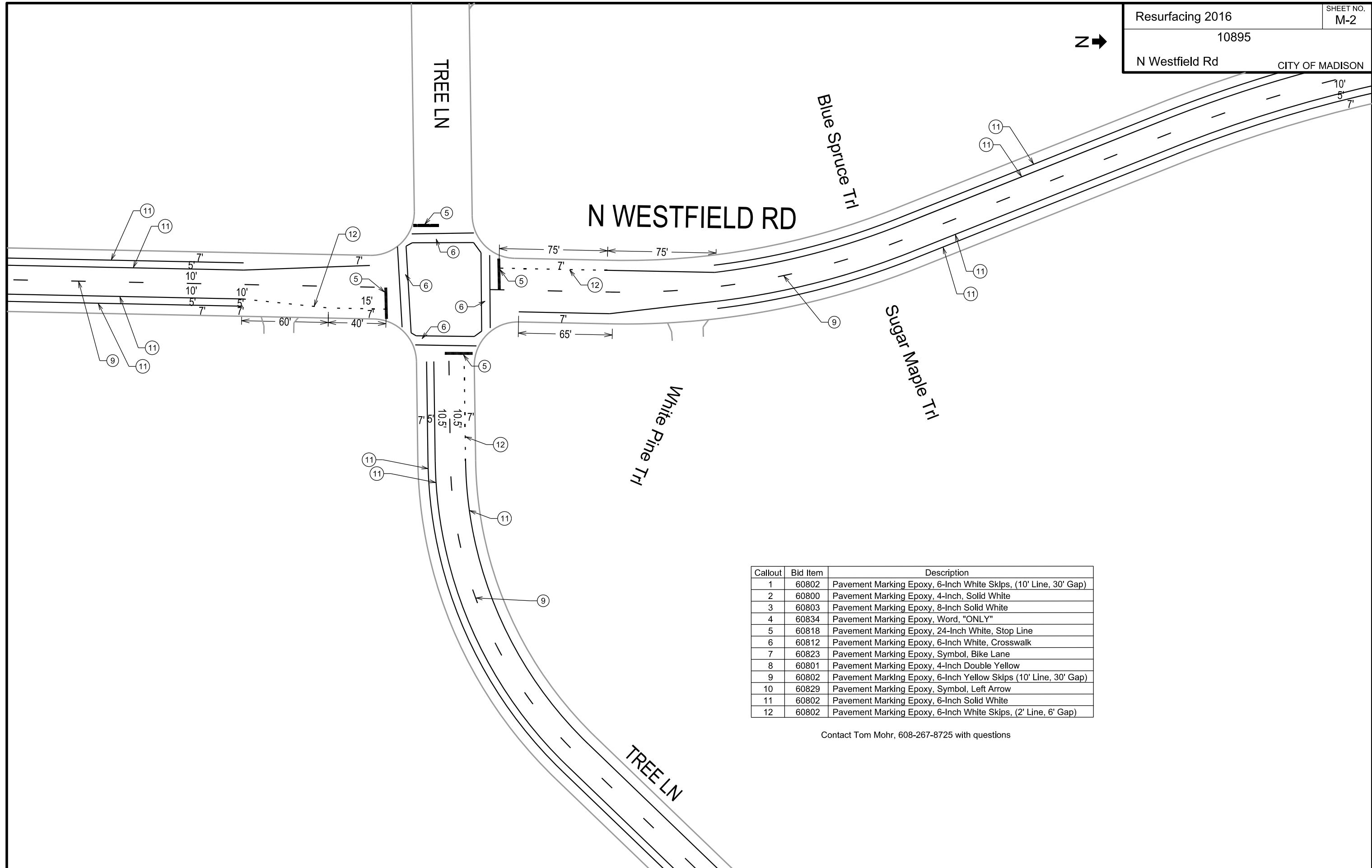

Callout	Bid Item	Description
1	60802	Pavement Marking Epoxy, 6-Inch White Skips, (10' Line, 30' Gap)
2	60800	Pavement Marking Epoxy, 4-Inch, Solid White
3	60803	Pavement Marking Epoxy, 8-Inch Solid White
4	60834	Pavement Marking Epoxy, Word, "ONLY"
5	60818	Pavement Marking Epoxy, 24-Inch White, Stop Line
6	60812	Pavement Marking Epoxy, 6-Inch White, Crosswalk
7	60823	Pavement Marking Epoxy, Symbol, Bike Lane
8	60801	Pavement Marking Epoxy, 4-Inch Double Yellow
9	60802	Pavement Marking Epoxy, 6-Inch Yellow Skips (10' Line, 30' Gap)
10	60829	Pavement Marking Epoxy, Symbol, Left Arrow
11	60802	Pavement Marking Epoxy, 6-Inch Solid White
12	60802	Pavement Marking Epoxy, 6-Inch White Skips, (2' Line, 6' Gap)

Contact Tom Mohr, 608-267-8725 with questions

PLOT SCALE:

PLOT NAME:

REV. DATE:

ORIGINATOR: CITY OF MADISON, TRAFFIC ENG. DIV.



PLOT SCALE:
 PLOT NAME:
 REV. DATE:
 ORIGINATOR: CITY OF MADISON, TRAFFIC ENG. DIV.

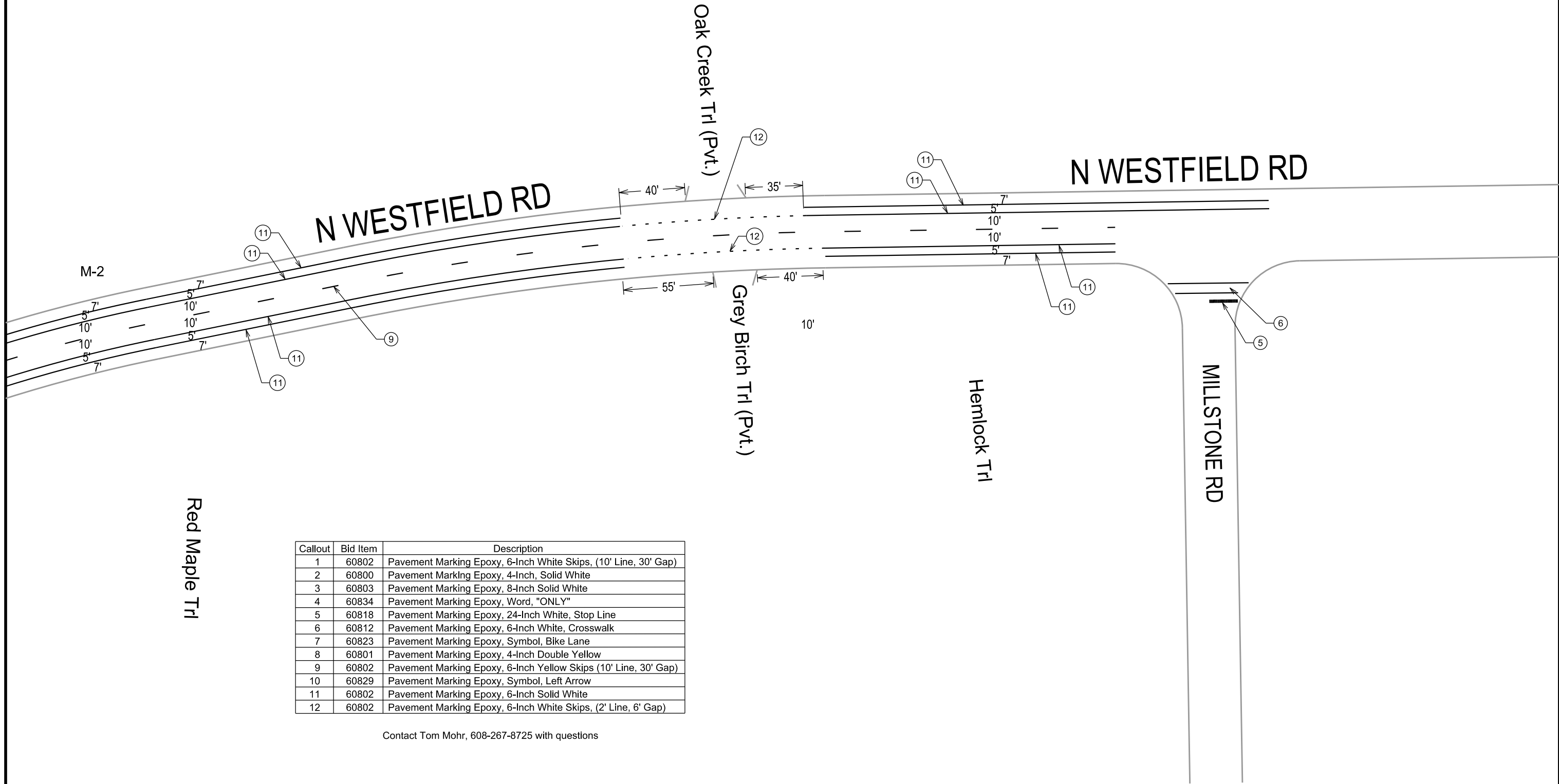

Callout	Bid Item	Description
1	60802	Pavement Marking Epoxy, 6-Inch White Skips, (10' Line, 30' Gap)
2	60800	Pavement Marking Epoxy, 4-Inch, Solid White
3	60803	Pavement Marking Epoxy, 8-Inch Solid White
4	60834	Pavement Marking Epoxy, Word, "ONLY"
5	60818	Pavement Marking Epoxy, 24-Inch White, Stop Line
6	60812	Pavement Marking Epoxy, 6-Inch White, Crosswalk
7	60823	Pavement Marking Epoxy, Symbol, Bike Lane
8	60801	Pavement Marking Epoxy, 4-Inch Double Yellow
9	60802	Pavement Marking Epoxy, 6-Inch Yellow Skips (10' Line, 30' Gap)
10	60829	Pavement Marking Epoxy, Symbol, Left Arrow
11	60802	Pavement Marking Epoxy, 6-Inch Solid White
12	60802	Pavement Marking Epoxy, 6-Inch White Skips, (2' Line, 6' Gap)

Contact Tom Mohr, 608-267-8725 with questions

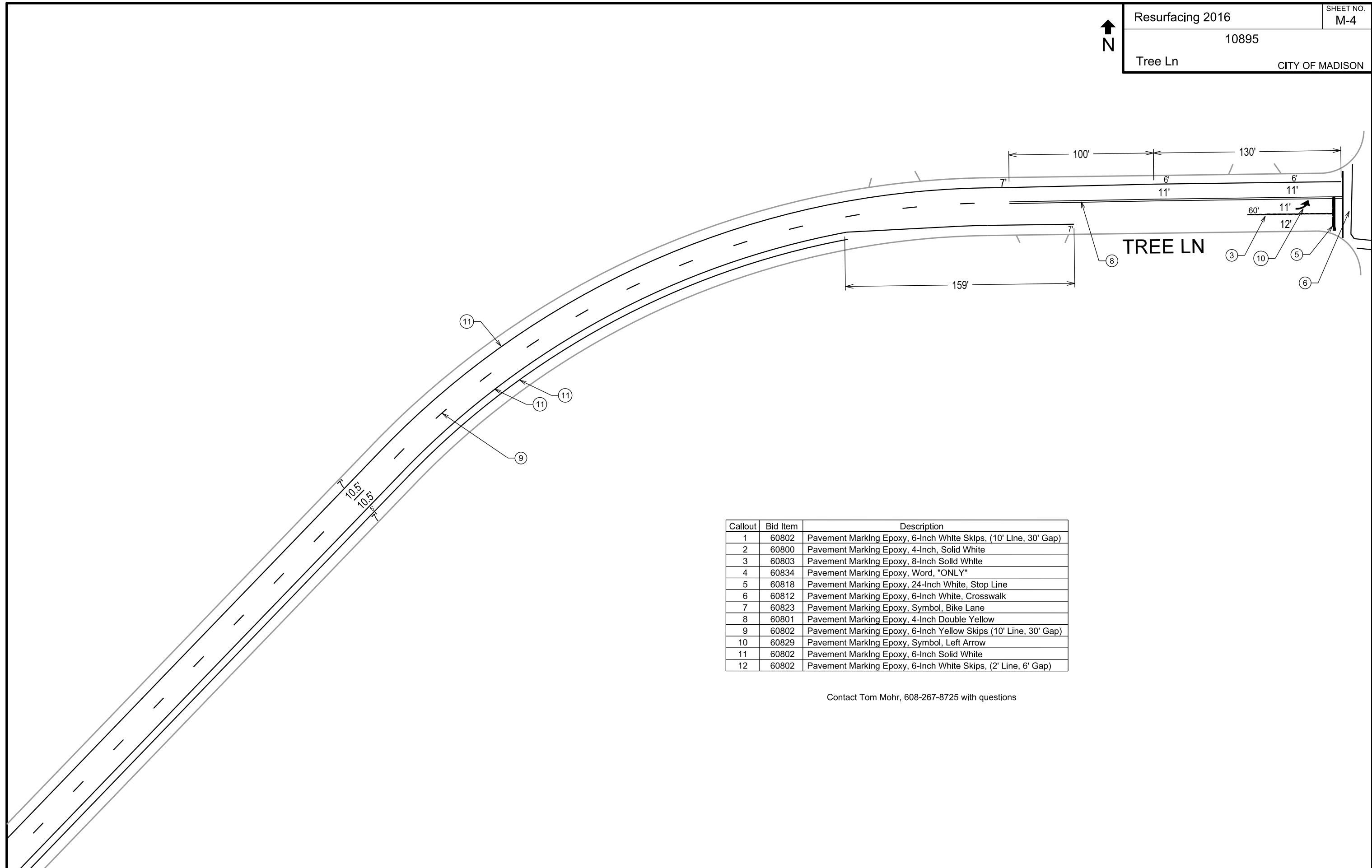

Callout	Bid Item	Description
1	60802	Pavement Marking Epoxy, 6-Inch White Skips, (10' Line, 30' Gap)
2	60800	Pavement Marking Epoxy, 4-Inch, Solid White
3	60803	Pavement Marking Epoxy, 8-Inch Solid White
4	60834	Pavement Marking Epoxy, Word, "ONLY"
5	60818	Pavement Marking Epoxy, 24-Inch White, Stop Line
6	60812	Pavement Marking Epoxy, 6-Inch White, Crosswalk
7	60823	Pavement Marking Epoxy, Symbol, Bike Lane
8	60801	Pavement Marking Epoxy, 4-Inch Double Yellow
9	60802	Pavement Marking Epoxy, 6-Inch Yellow Skips (10' Line, 30' Gap)
10	60829	Pavement Marking Epoxy, Symbol, Left Arrow
11	60802	Pavement Marking Epoxy, 6-Inch Solid White
12	60802	Pavement Marking Epoxy, 6-Inch White Skips, (2' Line, 6' Gap)

Contact Tom Mohr, 608-267-8725 with questions

PLOT SCALE:

PLOT NAME:

REV. DATE:

ORIGINATOR: CITY OF MADISON, TRAFFIC ENG. DIV.



PLOT SCALE:
 PLOT NAME:
 REV. DATE:
 ORIGINATOR: CITY OF MADISON, TRAFFIC ENG. DIV.

GRAND CANYON DR

NORMANDY LN

GRAND TETON PLAZA

Callout	Bid Item	Description
1	60802	Pavement Marking Epoxy, 6-Inch White Skips, (10' Line, 30' Gap)
2	60800	Pavement Marking Epoxy, 4-Inch, Solid White
3	60803	Pavement Marking Epoxy, 8-Inch Solid White
4	60834	Pavement Marking Epoxy, Word, "ONLY"
5	60818	Pavement Marking Epoxy, 24-Inch White, Stop Line
6	60812	Pavement Marking Epoxy, 6-Inch White, Crosswalk
7	60823	Pavement Marking Epoxy, Symbol, Bike Lane
8	60801	Pavement Marking Epoxy, 4-Inch Double Yellow
9	60802	Pavement Marking Epoxy, 6-Inch Yellow Skips (10' Line, 30' Gap)
10	60829	Pavement Marking Epoxy, Symbol, Left Arrow
11	60802	Pavement Marking Epoxy, 6-Inch Solid White
12	60802	Pavement Marking Epoxy, 6-Inch White Skips, (2' Line, 6' Gap)

Contact Tom Mohr, 608-267-8725 with questions

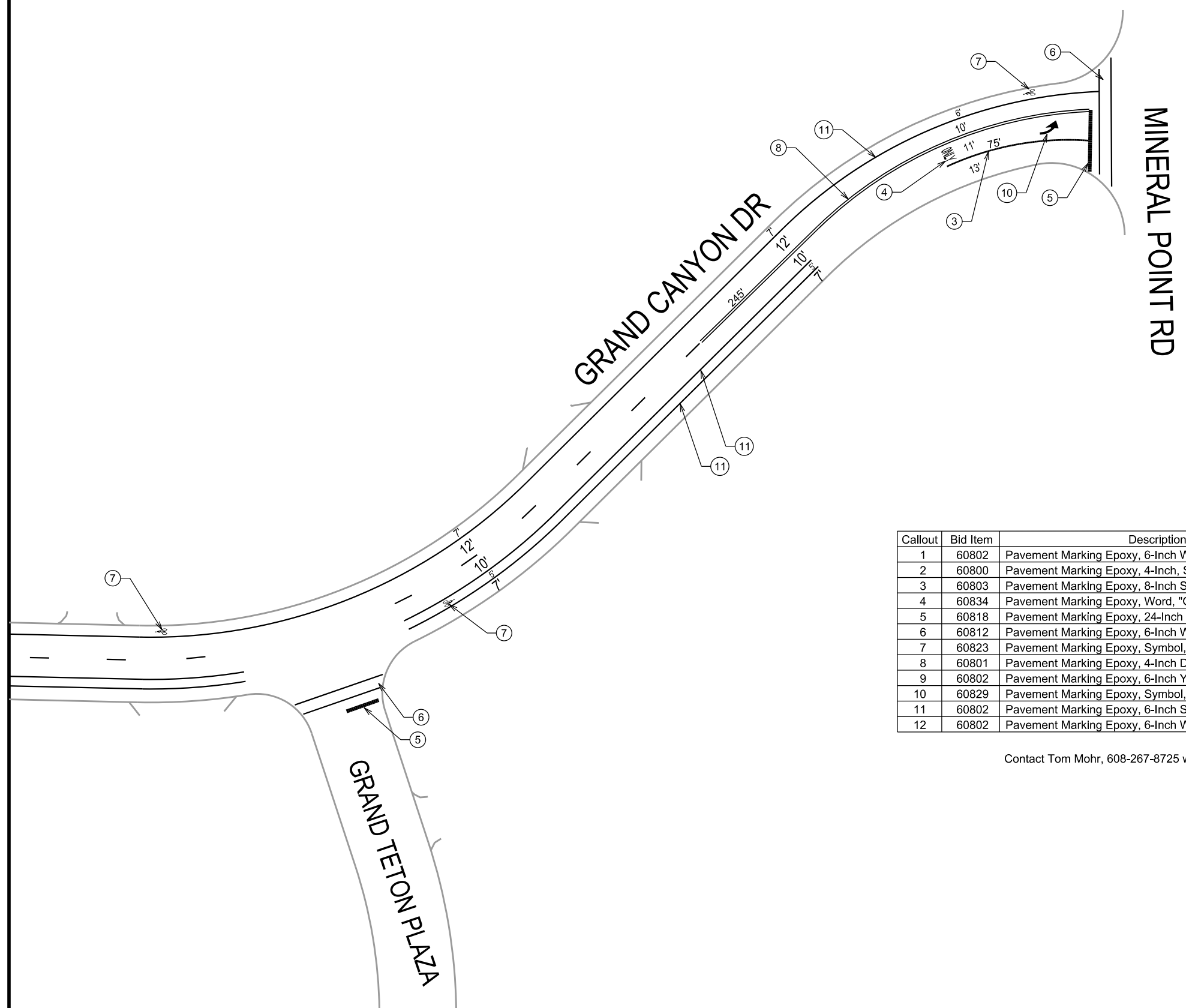

Callout	Bid Item	Description
1	60802	Pavement Marking Epoxy, 6-Inch White Skips, (10' Line, 30' Gap)
2	60800	Pavement Marking Epoxy, 4-Inch, Solid White
3	60803	Pavement Marking Epoxy, 8-Inch Solid White
4	60834	Pavement Marking Epoxy, Word, "ONLY"
5	60818	Pavement Marking Epoxy, 24-Inch White, Stop Line
6	60812	Pavement Marking Epoxy, 6-Inch White, Crosswalk
7	60823	Pavement Marking Epoxy, Symbol, Bike Lane
8	60801	Pavement Marking Epoxy, 4-Inch Double Yellow
9	60802	Pavement Marking Epoxy, 6-Inch Yellow Skips (10' Line, 30' Gap)
10	60829	Pavement Marking Epoxy, Symbol, Left Arrow
11	60802	Pavement Marking Epoxy, 6-Inch Solid White
12	60802	Pavement Marking Epoxy, 6-Inch White Skips, (2' Line, 6' Gap)

Contact Tom Mohr, 608-267-8725 with questions

PLOT SCALE:
 PLOT NAME:
 REV. DATE:
 ORIGINATOR: CITY OF MADISON, TRAFFIC ENG. DIV.

SECTION E: BIDDERS ACKNOWLEDGEMENT

**RESURFACING 2016 – ASPHALT PAVEMENT PULVERIZING, MILLING & PAVING
CONTRACT NO. 7616**

Bidder must state a Unit Price and Total Bid for each item. The Total Bid for each item must be the product of quantity, by Unit Price. The Grand Total must be the sum of the Total Bids for the various items. In case of multiplication errors or addition errors, the Grand Total with corrected multiplication and/or addition shall determine the Grand Total bid for each contract. The Unit Price and Total Bid must be entered numerically in the spaces provided. All words and numbers shall be written in ink.

1. The undersigned having familiarized himself/herself with the Contract documents, including Advertisement for Bids, Instructions to Bidders, Form of Proposal, City of Madison Standard Specifications for Public Works Construction - 2015 Edition thereto, Form of Agreement, Form of Bond, and Addenda issued and attached to the plans and specifications on file in the office of the City Engineer, hereby proposes to provide and furnish all the labor, materials, tools, and expendable equipment necessary to perform and complete in a workmanlike manner the specified construction on this project for the City of Madison; all in accordance with the plans and specifications as prepared by the City Engineer, including Addenda to the Contract Nos. _____ through _____ issued thereto, at the prices for said work as contained in this proposal. (Electronic bids submittals shall acknowledge addendum under Section E and shall not acknowledge here)
2. If awarded the Contract, we will initiate action within seven (7) days after notification or in accordance with the date specified in the contract to begin work and will proceed with diligence to bring the project to full completion within the number of work days allowed in the Contract or by the calendar date stated in the Contract.
3. The undersigned Bidder or Contractor certifies that he/she is not a party to any contract, combination in form of trust or otherwise, or conspiracy in restraint of trade or commerce or any other violation of the anti-trust laws of the State of Wisconsin or of the United States, with respect to this bid or contract or otherwise.
4. I hereby certify that I have met the Bid Bond Requirements as specified in Section 102.5. *(IF BID BOND IS USED, IT SHALL BE SUBMITTED ON THE FORMS PROVIDED BY THE CITY. FAILURE TO DO SO MAY RESULT IN REJECTION OF THE BID).*
5. I hereby certify that all statements herein are made on behalf of _____ (name of corporation, partnership, or person submitting bid) a corporation organized and existing under the laws of the State of _____ a partnership consisting of _____; an individual trading as _____; of the City of _____ State of _____; that I have examined and carefully prepared this Proposal, from the plans and specifications and have checked the same in detail before submitting this Proposal; that I have fully authority to make such statements and submit this Proposal in (its, their) behalf; and that the said statements are true and correct.

SIGNATURE

TITLE, IF ANY

Sworn and subscribed to before me this _____ day of _____, 20_____.

(Notary Public or other officer authorized to administer oaths)
My Commission Expires _____

Bidders shall not add any conditions or qualifying statements to this Proposal.

SECTION F: DISCLOSURE OF OWNERSHIP & BEST VALUE CONTRACTING

RESURFACING 2016 – ASPHALT PAVEMENT PULVERIZING, MILLING & PAVING CONTRACT NO. 7616

State of Wisconsin
Department of Workforce Development
Equal Rights Division
Labor Standards Bureau

Disclosure of Ownership

<p>Notice required under Section 15.04(1)(m), Wisconsin Statutes. The statutory authority for the use of this form is prescribed in Sections 66.0903(12)(d) and 103.49(7)(d), Wisconsin Statutes. The use of this form is mandatory. The penalty for failing to complete this form is prescribed in Section 103.005(12), Wisconsin Statutes. Personal information you provide may be used for secondary purposes.</p>			
<p>(1) On the date a contractor submits a bid to or completes negotiations with a state agency or local governmental unit, on a project subject to Section 66.0903 or 103.49, Wisconsin Statutes, the contractor shall disclose to such state agency or local governmental unit the name of any "other construction business", which the contractor, or a shareholder, officer or partner of the contractor, owns or has owned within the preceding three (3) years.</p> <p>(2) The term "other construction business" means any business engaged in the erection, construction, remodeling, repairing, demolition, altering or painting and decorating of buildings, structures or facilities. It also means any business engaged in supplying mineral aggregate, or hauling excavated material or spoil as provided by Sections 66.0903(3), 103.49(2) and 103.50(2), Wisconsin Statutes.</p> <p>(3) This form must ONLY be filed, with the state agency or local governmental unit that will be awarding the contract, if both (A) and (B) are met.</p> <p>(A) The contractor, or a shareholder, officer or partner of the contractor:</p> <p style="margin-left: 20px;">(1) Owns at least a 25% interest in the "other construction business", indicated below, on the date the contractor submits a bid or completes negotiations.</p> <p style="margin-left: 20px;">(2) Or has owned at least a 25% interest in the "other construction business" at any time within the preceding three (3) years.</p> <p>(B) The Wisconsin Department of Workforce Development (DWD) has determined that the "other construction business" has failed to pay the prevailing wage rate or time and one-half the required hourly basic rate of pay, for hours worked in excess of the prevailing hours of labor, to any employee at any time within the preceding three (3) years.</p>			
Other Construction Business			
Not Applicable <input type="checkbox"/>			
Name of Business			
Street Address or P O Box	City	State	Zip Code
Name of Business			
Street Address or P O Box	City	State	Zip Code
Name of Business			
Street Address or P O Box	City	State	Zip Code
<p>I hereby state under penalty of perjury that the information, contained in this document, is true and accurate according to my knowledge and belief.</p>			
Print the Name of Authorized Officer			
Signature of Authorized Officer		Date Signed	
Name of Corporation, Partnership or Sole Proprietorship			
Street Address or P O Box	City	State	Zip Code

If you have any questions call (608) 266-0028

ERD-7777-E (R. 09/2003)

**RESURFACING 2016 – ASPHALT PAVEMENT PULVERIZING, MILLING & PAVING
CONTRACT NO. 7616**

Best Value Contracting

1. The Contractor shall indicate the non-apprenticeable trades used on this contract.

2. Madison General Ordinance (M.G.O.), 33.07(7), does provide for some exemptions from the active apprentice requirement. Apprenticeable trades are those trades considered apprenticeable by the State of Wisconsin. Please check applicable box if you are seeking an exemption.

- Contractor has a total skilled workforce of four or less individuals in all apprenticeable trades combined.
- No available trade training program; The Contractor has been rejected by the only available trade training program, or there is no trade training program within 90 miles.
- Contractor is not using an apprentice due to having a journey worker on layoff status, provided the journey worker was employed by the contractor in the past six months.
- First-time Contractor on City of Madison Public Works contract requests a onetime exemption but intends to comply on all future contracts and is taking steps typical of a "good faith" effort.
- Contractor has been in business less than one year.
- Contractor doesn't have enough journeyman trade workers to qualify for a trade training program in that respective trade

3. The Contractor shall indicate on the following section which apprenticeable trades are to be used on this contract. Compliance with active apprenticeship, to the extent required by M.G.O. 33.07(7), shall be satisfied by documentation from an applicable trade training body; an apprenticeship contract with the Wisconsin Department of Workforce Development or a similar agency in another state; or the U.S Department of Labor. This documentation is required prior to the Contractor beginning work on the project site.

- The Contractor has reviewed the list and shall not use any apprenticeable trades on this project.

LIST APPRENTICABLE TRADES (check all that apply to your work to be performed on this contract)

- BRICKLAYER
- CARPENTER
- CEMENT MASON / CONCRETE FINISHER
- CEMENT MASON (HEAVY HIGHWAY)
- CONSTRUCTION CRAFT LABORER
- DATA COMMUNICATION INSTALLER
- ELECTRICIAN
- ENVIRONMENTAL SYSTEMS TECHNICIAN / HVAC SERVICE TECH/HVAC INSTALL / SERVICE
- GLAZIER
- HEAVY EQUIPMENT OPERATOR / OPERATING ENGINEER
- INSULATION WORKER (HEAT & FROST)
- IRON WORKER
- IRON WORKER (ASSEMBLER, METAL BLDGS)
- PAINTER & DECORATOR
- PLASTERER
- PLUMBER
- RESIDENTIAL ELECTRICIAN
- ROOFER & WATER PROOFER
- SHEET METAL WORKER
- SPRINKLER FITTER
- STEAMFITTER
- STEAMFITTER (REFRIGERATION)
- STEAMFITTER (SERVICE)
- TAPER & FINISHER
- TELECOMMUNICATIONS (VOICE, DATA & VIDEO) INSTALLER-TECHNICIAN
- TILE SETTER

SECTION G: BID BOND

KNOW ALL MEN BY THESE PRESENT, THAT _____
(a corporation of the State of _____) (individual), (partnership),
hereinafter referred to as the "Principal") and _____,
a corporation of the State of _____ (hereinafter referred to as the "Surety")
and licensed to do business in the State of Wisconsin, are held and firmly bound unto the City of
Madison, (hereinafter referred to as the "Obligee"), in the sum of five per cent (5%) of the amount of the
total bid or bids of the Principal herein accepted by the Obligee, for the payment of which the Principal
and the Surety bind themselves, their heirs, executors, administrators, successors and assigns, jointly
and severally, firmly by these presents.

The conditions of this obligation are such that, whereas the Principal has submitted, to the City of
Madison a certain bid, including the related alternate, and substitute bids attached hereto and hereby
made a part hereof, to enter into a contract in writing for the construction of:

RESURFACING 2016 – ASPHALT PAVEMENT PULVERIZING, MILLING & PAVING CONTRACT NO. 7616

1. If said bid is rejected by the Obligee, then this obligation shall be void.
2. If said bid is accepted by the Obligee and the Principal shall execute and deliver a contract in the
form specified by the Obligee (properly completed in accordance with said bid) and shall furnish a
bond for his/her faithful performance of said contract, and for the payment of all persons
performing labor or furnishing materials in connection therewith, and shall in all other respects
perform the agreement created by the acceptance of said bid, then this obligation shall be void.

If said bid is accepted by the Obligee and the Principal shall fail to execute and deliver the
contract and the performance and payment bond noted in 2. above executed by this Surety, or
other Surety approved by the City of Madison, all within the time specified or any extension
thereof, the Principal and Surety agree jointly and severally to forfeit to the Obligee as liquidated
damages the sum mentioned above, it being understood that the liability of the Surety for any and
all claims hereunder shall in no event exceed the sum of this obligation as stated, and it is further
understood that the Principal and Surety reserve the right to recover from the Obligee that portion
of the forfeited sum which exceed the actual liquidated damages incurred by the Obligee.

The Surety, for value received, hereby stipulates and agrees that the obligations of said Surety
and its bond shall be in no way impaired or affected by an extension of the time within which the
Obligee may accept such bid, and said Surety does hereby waive notice of any such extension.

IN WITNESS WHEREOF, the Principal and the Surety have hereunto set their hands and seals, and such of them as are corporations have caused their corporate seals to be hereto affixed and these presents to be signed by their proper officers, on the day and year set forth below.

Seal

Principal Date

By:

Name of Surety

By:

Date

This certifies that I have been duly licensed as an agent for the above company in Wisconsin under National Producer Number _____ for the year _____, and appointed as attorney in fact with authority to execute this bid bond and the payment and performance bond referred to above, which power of attorney has not been revoked.

Date

Agent

Address

City, State and Zip Code

Telephone Number

NOTE TO SURETY & PRINCIPAL

The bid submitted which this bond guarantees shall be rejected if the following instrument is not attached to this bond:

Power of Attorney showing that the agent of Surety is currently authorized to execute bonds on behalf of the Surety, and in the amounts referenced above.

Certificate of Biennial Bid Bond

TIME PERIOD - VALID (FROM/TO)
NAME OF SURETY
NAME OF CONTRACTOR
CERTIFICATE HOLDER <p style="text-align: center;">City of Madison, Wisconsin</p>

This is to certify that a biennial bid bond issued by the above-named Surety is currently on file with the City of Madison.

This certificate is issued as a matter of information and conveys no rights upon the certificate holder and does not amend, extend or alter the coverage of the biennial bid bond.

Cancellation: Should the above policy be cancelled before the expiration date, the issuing Surety will give thirty (30) days written notice to the certificate holder indicated above.

Signature of Authorized Contractor Representative

Date

SECTION H: AGREEMENT

THIS AGREEMENT made this _____ day of _____ in the year Two Thousand and Fifteen between _____ hereinafter called the Contractor, and the City of Madison, Wisconsin, hereinafter called the City.

WHEREAS, the Common Council of the said City of Madison under the provisions of a resolution adopted _____, and by virtue of authority vested in the said Council, has awarded to the Contractor the work of performing certain construction.

NOW, THEREFORE, the Contractor and the City, for the consideration hereinafter named, agree as follows:

1. **Scope of Work.** The Contractor shall, perform the construction, execution and completion of the following listed complete work or improvement in full compliance with the Plans, Specifications, Standard Specifications, Supplemental Specifications, Special Provisions and contract; perform all items of work covered or stipulated in the proposal; perform all altered or extra work; and shall furnish, unless otherwise provided in the contract, all materials, implements, machinery, equipment, tools, supplies, transportation, and labor necessary to the prosecution and completion of the work or improvements:

RESURFACING 2016 – ASPHALT PAVEMENT PULVERIZING, MILLING & PAVING CONTRACT NO. 7616

2. **Completion Date/Contract Time.** Construction work must begin within seven (7) calendar days after the date appearing on mailed written notice to do so shall have been sent to the Contractor and shall be carried on at a rate so as to secure full completion SEE SPECIAL PROVISIONS, the rate of progress and the time of completion being essential conditions of this Agreement.
3. **Contract Price.** The City shall pay to the Contractor at the times, in the manner and on the conditions set forth in said specifications, the sum of _____ (\$ _____) Dollars being the amount bid by such Contractor and which was awarded to him/her as provided by law.
4. **Wage Rates for Employees of Public Works Contractors**

General and Authorization. The Contractor shall compensate its employees at the prevailing wage rate in accordance with section 66.0903, Wis. Stats., DWD 290 of the Wisconsin Administrative Code and as hereinafter provided unless otherwise noted in Section D: Special Provisions, Subsection 102.10 – Minimum Rate of Wage Scale.

“Public Works” shall include building or work involving the erection, construction, remodeling, repairing or demolition of buildings, parking lots, highways, streets, bridges, sidewalks, street lighting, traffic signals, sanitary sewers, water mains and appurtenances, storm sewers, and the grading and landscaping of public lands.

“Building or work” includes construction activity as distinguished from manufacturing, furnishing of materials, or servicing and maintenance work, except for the delivery of mineral aggregate such as sand, gravel, bituminous asphaltic concrete or stone which is incorporated into the work under contract with the City by depositing the material directly in final place from transporting vehicle.

“Erection, construction, remodeling, repairing” means all types of work done on a particular building or work at the site thereof in the construction or development of the project, including without limitation, erecting, construction, remodeling, repairing, altering, painting, and decorating, the transporting of materials and supplies to or from the building or work done by the employees of the Contractor, Subcontractor, or Agent thereof, and the manufacturing or furnishing of

materials, articles, supplies or equipment on the site of the building or work, by persons employed by the Contractor, Subcontractor, or Agent thereof.

"Employees working on the project" means laborers, workers, and mechanics employed directly upon the site of work.

"Laborers, Workers, and Mechanics" include pre-apprentices, helpers, trainees, learners and properly registered and indentured apprentices but exclude clerical, supervisory, and other personnel not performing manual labor.

Establishment of Wage Rates. The Department of Public Works shall periodically obtain a current schedule of prevailing wage rates from DWD. The schedule shall be used to establish the City of Madison Prevailing Wage Rate Schedule for Public Works Construction (prevailing wage rate). The Department of Public Works may include known increases to the prevailing wage rate which can be documented and are to occur on a future specific date. The prevailing wage rate shall be included in public works contracts subsequently negotiated or solicited by the City. Except for known increases contained within the schedule, the prevailing wage rate shall not change during the contract. The approved wage rate is attached hereto.

Workforce Profile. The Contractor shall, at the time of signature of the contract, notify the City Engineer in writing of the names and classifications of all the employees of the Contractor, Subcontractors, and Agents proposed for the work. In the alternative, the Contractor shall submit in writing the classifications of all the employees of the Contractor, Subcontractors and Agents and the total number of hours estimated in each classification for the work. This workforce profile(s) shall be reviewed by the City Engineer who may, within ten (10) days, object to the workforce profile(s) as not being reflective of that which would be required for the work. The Contractor may request that the workforce profile, or a portion of the workforce profile, be submitted after the signature of the contract but at least ten (10) days prior to the work commencing. Any costs or time loss resulting from modifications to the workforce profile as a result of the City Engineer's objections shall be the responsibility of the Contractor.

Payrolls and Records. The Contractor shall keep weekly payroll records setting forth the name, address, telephone number, classification, wage rate and fringe benefit package of all the employees who work on the contract, including the employees of the Contractor's subcontractors and agents. Such weekly payroll records must include the required information for all City contracts and all other contracts on which the employee worked during the week in which the employee worked on the contract. The Contractor shall also keep records of the individual time each employee worked on the project and for each day of the project. Such records shall also set forth the total number of hours of overtime credited to each such employee for each day and week and the amount of overtime pay received in that week. The records shall set forth the full weekly wages earned by each employee and the actual hourly wage paid to the employee.

The Contractor shall submit the weekly payroll records, including the records of the Contractor's subcontractors and agents, to the City Engineer for every week that work is being done on the contract. The submittal shall be within twenty-one (21) calendar days of the end of the Contractor's weekly pay period.

Employees shall receive the full amounts accrued at the time of the payment, computed at rates not less than those stated in the prevailing wage rate and each employee's rate shall be determined by the work that is done within the trade or occupation classification which should be properly assigned to the employee.

An employee's classification shall not be changed to a classification of a lesser rate during the contract. If, during the term of the contract, an employee works in a higher pay classification than the one which was previously properly assigned to the employee, then that employee shall be considered to be in the higher pay classification for the balance of the contract, receive the appropriate higher rate of pay, and she/he shall not receive a lesser rate during the balance of the

contract. For purposes of clarification, it is noted that there is a distinct difference between working in a different classification with higher pay and doing work within a classification that has varying rates of pay which are determined by the type of work that is done within the classification. For example, the classification "Operating Engineer" provides for different rates of pay for various classes of work and the Employer shall compensate an employee classified as an "Operating Engineer" based on the highest class of work that is done in one day. Therefore, an "Operating Engineer's" rate may vary on a day to day basis depending on the type of work that is done, but it will never be less than the base rate of an "Operating Engineer". Also, as a matter of clarification, it is recognized that an employee may work in a higher paying classification merely by chance and without prior intention, calculation or design. If such is the case and the performance of the work is truly incidental and the occurrence is infrequent, inconsequential and does not serve to undermine the single classification principle herein, then it may not be required that the employee be considered to be in the higher pay classification and receive the higher rate of pay for the duration of the contract. However, the Contractor is not precluded or prevented from paying the higher rate for the limited time that an employee performs work that is outside of the employee's proper classification.

Questions regarding an employee's classification, rate of pay or rate of pay within a classification, shall be resolved by reference to the established practice that predominates in the industry and on which the trade or occupation rate/classification is based. Rate of pay and classification disputes shall be resolved by relying upon practices established by collective bargaining agreements and guidelines used in such determination by appropriate recognized trade unions operating within the City of Madison.

The Contractor, its Subcontractors and Agents shall submit to interrogation regarding compliance with the provisions of this ordinance.

Mulcting of the employees by the Contractor, Subcontractor, and Agents on Public Works contracts, such as by kickbacks or other devices, is prohibited. The normal rate of wage of the employees of the Contractor, Subcontractor, and Agents shall not be reduced or otherwise diminished as a result of payment of the prevailing wage rate on a public works contract.

Hourly contributions. Hourly contributions shall be determined in accordance with the prevailing wage rate and with DWD. 290.01(10), Wis. Admin. Code.

Apprentices and Subjourney persons. Apprentices and sub journeypersons performing work on the project shall be compensated in accordance with the prevailing wage rate and with DWD 290.02, and 290.025, respectively, Wis. Admin. Code.

Straight Time Wages. The Contractor may pay straight time wages as determined by the prevailing wage rate and DWD 290.04, Wis. Admin. Code.

Overtime Wages. The Contractor shall pay overtime wages as required by the prevailing wage rate and DWD 290.05, Wis. Admin. Code.

Posting of Wage Rates and Hours. A clearly legible copy of the prevailing wage rate, together with the provisions of Sec. 66.0903(10)(a) and (11)(a), Wis. Stats., shall be kept posted in at least one conspicuous and easily accessible place at the project site by the Contractor and such notice shall remain posted during the full time any laborers, workers or mechanics are employed on the contract.

Evidence of Compliance by Contractor. Upon completion of the contract, the Contractor shall file with the Department of Public Works an affidavit stating:

- a. That the Contractor has complied fully with the provisions and requirements of Sec. 66.0903(3), Wis. Stats., and Chapter DWD 290, Wis. Admin. Code; the Contractor has received evidence of compliance from each of the agents and subcontractors; and the

names and addresses of all of the subcontractors and agents who worked on the contract.

- b. That full and accurate records have been kept, which clearly indicate the name and trade or occupation of every laborer, worker or mechanic employed by the Contractor in connection with work on the project. The records shall show the number of hours worked by each employee and the actual wages paid therefore; where these records will be kept and the name, address and telephone number of the person who will be responsible for keeping them. The records shall be retained and made available for a period of at least three (3) years following the completion of the project of public works and shall not be removed without prior notification to the municipality.

Evidence of Compliance by Agent and Subcontractor. Each agent and subcontractor shall file with the Contractor, upon completion of their portion of the work on the contract an affidavit stating that all the provisions of Sec. 66.0903(3), Wis. Stats., have been fully complied with and that full and accurate records have been kept, which clearly indicate the name and trade or occupation of every laborer, worker or mechanic employed by the Contractor in connection with work on the project. The records shall show the number of hours worked by each employee and the actual wages paid therefore; where these records shall be kept and the name, address and telephone number of the person who shall be responsible for keeping them. The records shall be retained and made available for a period of at least three (3) years following the completion of the project of public works and shall not be removed without prior notification to the municipality.

Failure to Comply with the Prevailing Wage Rate. If the Contractor fails to comply with the prevailing wage rate, she/he shall be in default on the contract. In addition, if DWD finds that a contractor or subcontractor violated the prevailing wage law, DWD will assess liquidated damages of 100% of the wages owed to employees.

Establishment of Wage Rates. The Department of Public Works shall periodically obtain a current schedule of prevailing wage rates from DWD. The schedule shall be used to establish the City of Madison Prevailing Wage Rate Schedule for Public Works Construction (prevailing wage rate). The Department of Public Works may include known increases to the prevailing wage rate which can be documented and are to occur on a future specific date. The prevailing wage rate shall be included in public works contracts subsequently negotiated or solicited by the City. Except for known increases contained within the schedule, the prevailing wage rate shall not change during the contract. The approved wage rate and DWD prevailing wage requirements are attached hereto as Sec. I of the contract.

5. **Affirmative Action.** In the performance of the services under this Agreement the Contractor agrees not to discriminate against any employee or applicant because of race, religion, marital status, age, color, sex, disability, national origin or ancestry, income level or source of income, arrest record or conviction record, less than honorable discharge, physical appearance, sexual orientation, gender identity, political beliefs, or student status. The Contractor further agrees not to discriminate against any subcontractor or person who offers to subcontract on this contract because of race, religion, color, age, disability, sex, sexual orientation, gender identity or national origin.

The Contractor agrees that within thirty (30) days after the effective date of this agreement, the Contractor will provide to the City Affirmative Action Division certain workforce utilization statistics, using a form to be furnished by the City.

If the contract is still in effect, or if the City enters into a new agreement with the Contractor, within one year after the date on which the form was required to be provided, the Contractor will provide updated workforce information using a second form, also to be furnished by the City. The second form will be submitted to the City Affirmative Action Division no later than one year after the date on which the first form was required to be provided.

The Contractor further agrees that, for at least twelve (12) months after the effective date of this contract, it will notify the City Affirmative Action Division of each of its job openings at facilities in Dane County for which applicants not already employees of the Contractor are to be considered. The notice will include a job description, classification, qualifications and application procedures and deadlines. The Contractor agrees to interview and consider candidates referred by the Affirmative Action Division if the candidate meets the minimum qualification standards established by the Contractor, and if the referral is timely. A referral is timely if it is received by the Contractor on or before the date started in the notice.

Articles of Agreement Article I

The Contractor shall take affirmative action in accordance with the provisions of this contract to insure that applicants are employed, and that employees are treated during employment without regard to race, religion, color, age, marital status, disability, sex, sexual orientation, gender identity or national origin and that the employer shall provide harassment free work environment for the realization of the potential of each employee. Such action shall include, but not be limited to, the following: employment, upgrading, demotion or transfer, recruitment or recruitment advertising, layoff or termination, rates of pay or other forms of compensation and selection for training including apprenticeship insofar as it is within the control of the Contractor. The Contractor agrees to post in conspicuous places available to employees and applicants notices to be provided by the City setting out the provisions of the nondiscrimination clauses in this contract.

Article II

The Contractor shall in all solicitations or advertisements for employees placed by or on behalf of the Contractors state that all qualified or qualifiable applicants will be employed without regard to race, religion, color, age, marital status, disability, sex, sexual orientation, gender identity or national origin.

Article III

The Contractor shall send to each labor union or representative of workers with which it has a collective bargaining agreement or other contract or understanding a notice to be provided by the City advising the labor union or worker's representative of the Contractor's equal employment opportunity and affirmative action commitments. Such notices shall be posted in conspicuous places available to employees and applicants for employment.

Article V

The Contractor agrees that it will comply with all provisions of the Affirmative Action Ordinance of the City of Madison, including the contract compliance requirements. The Contractor agrees to submit the model affirmative action plan for public works contractors in a form approved by the Affirmative Action Division Manager.

Article VI

The Contractor will maintain records as required by Section 39.02(9)(f) of the Madison General Ordinances and will provide the City Affirmative Action Division with access to such records and to persons who have relevant and necessary information, as provided in Section 39.02(9)(f). The City agrees to keep all such records confidential, except to the extent that public inspection is required by law.

Article VII

In the event of the Contractor's or subcontractor's failure to comply with the Equal Employment Opportunity and Affirmative Action Provisions of this contract or Section 39.03 and 39.02 of the Madison General Ordinances, it is agreed that the City at its option may do any or all of the following:

1. Cancel, terminate or suspend this Contract in whole or in part.
2. Declare the Contractor ineligible for further City contracts until the Affirmative Action requirements are met.
3. Recover on behalf of the City from the prime Contractor 0.5 percent of the contract award price for each week that such party fails or refuses to comply, in the nature of liquidated damages, but not to exceed a total of five percent (5%) of the contract price, or five thousand dollars (\$5,000), whichever is less. Under public works contracts, if a subcontractor is in noncompliance, the City may recover liquidated damages from the prime Contractor in the manner described above. The preceding sentence shall not be construed to prohibit a prime Contractor from recovering the amount of such damage from the non-complying subcontractor.

Article VIII

The Contractor shall include the above provisions of this contract in every subcontract so that such provisions will be binding upon each subcontractor. The Contractor shall take such action with respect to any subcontractor as necessary to enforce such provisions, including sanctions provided for noncompliance.

Article IX

The Contractor shall allow the maximum feasible opportunity to small business enterprises to compete for any subcontracts entered into pursuant to this contract. (In federally funded contracts the terms "DBE, MBE and WBE" shall be substituted for the term "small business" in this Article.)

6. Substance Abuse Prevention Program Required. Prior to commencing work on the Contract, the Contractor, and any Subcontractor, shall have in place a written program for the prevention of substance abuse among its employees as required under Wis. Stat. Sec. 103.503.
7. **Contractor Hiring Practices.**

Ban the Box - Arrest and Criminal Background Checks. (Sec. 39.08, MGO)

This provision applies to all prime contractors on contracts entered into on or after January 1, 2016, and all subcontractors who are required to meet prequalification requirements under MGO 33.07(7)(l), MGO as of the first time they seek or renew pre-qualification status on or after January 1, 2016. The City will monitor compliance of subcontractors through the pre-qualification process.

- a. **Definitions.** For purposes of this section, "Arrest and Conviction Record" includes, but is not limited to, information indicating that a person has been questioned, apprehended, taken into custody or detention, held for investigation, arrested, charged with, indicted or tried for any felony, misdemeanor or other offense pursuant to any law enforcement or military authority.

"Conviction record" includes, but is not limited to, information indicating that a person has been convicted of a felony, misdemeanor or other offense, placed on probation, fined, imprisoned or paroled pursuant to any law enforcement or military authority.

“Background Check” means the process of checking an applicant’s arrest and conviction record, through any means.

b. Requirements. For the duration of this Contract, the Contractor shall:

1. Remove from all job application forms any questions, check boxes, or other inquiries regarding an applicant’s arrest and conviction record, as defined herein.
2. Refrain from asking an applicant in any manner about their arrest or conviction record until after conditional offer of employment is made to the applicant in question.
3. Refrain from conducting a formal or informal background check or making any other inquiry using any privately or publicly available means of obtaining the arrest or conviction record of an applicant until after a conditional offer of employment is made to the applicant in question.
4. Make information about this ordinance available to applicants and existing employees, and post notices in prominent locations at the workplace with information about the ordinance and complaint procedure using language provided by the City.
5. Comply with all other provisions of Sec. 39.08, MGO.

c. Exemptions: This section shall not apply when:

1. Hiring for a position where certain convictions or violations are a bar to employment in that position under applicable law, or
2. Hiring a position for which information about criminal or arrest record, or a background check is required by law to be performed at a time or in a manner that would otherwise be prohibited by this ordinance, including a licensed trade or profession where the licensing authority explicitly authorizes or requires the inquiry in question.

To be exempt, Contractor has the burden of demonstrating that there is an applicable law or regulation that requires the hiring practice in question, if so, the contractor is exempt from all of the requirements of this ordinance for the position(s) in question.

**RESURFACING 2016 – ASPHALT PAVEMENT PULVERIZING, MILLING & PAVING
CONTRACT NO. 7616**

IN WITNESS WHEREOF, the Contractor has hereunto set his/her hand and seal and the City has caused these presents to be sealed with its corporate seal and to be subscribed by its Mayor and City Clerk the day and year first above written.

Countersigned:

		Company Name	
_____	Date	_____	Date
Witness		President	
_____	Date	_____	Date
Witness		Secretary	

CITY OF MADISON, WISCONSIN

Provisions have been made to pay the liability that will accrue under this contract.

Approved as to form:

_____		_____	
Finance Director		City Attorney	
Signed this _____ day of _____, 20_____			
_____		_____	Date
Witness		Mayor	
_____		_____	Date
Witness		City Clerk	

SECTION I: PAYMENT AND PERFORMANCE BOND

KNOW ALL MEN BY THESE PRESENTS, that we _____
as _____ principal, _____ and

Company of _____ as surety, are held and firmly bound unto the City of
Madison, Wisconsin, in the sum of _____ (\$_____) Dollars, lawful money of the
United States, for the payment of which sum to the City of Madison, we hereby bind ourselves and our
respective executors and administrators firmly by these presents.

The condition of this Bond is such that if the above bounden shall on his/her part fully and faithfully
perform all of the terms of the Contract entered into between him/herself and the City of Madison for the
construction of:

**RESURFACING 2016 – ASPHALT PAVEMENT PULVERIZING, MILLING & PAVING
CONTRACT NO. 7616**

in Madison, Wisconsin, and shall pay all claims for labor performed and material furnished in the
prosecution of said work, and save the City harmless from all claims for damages because of negligence
in the prosecution of said work, and shall save harmless the said City from all claims for compensation
(under Chapter 102, Wisconsin Statutes) of employees and employees of subcontractor, then this Bond is
to be void, otherwise of full force, virtue and effect.

Signed and sealed this _____ day of _____

Countersigned:

Company Name (Principal)

Witness

President Seal

Secretary

Approved as to form:

Surety Seal

Salary Employee Commission

City Attorney

By _____
Attorney-in-Fact

This certifies that I have been duly licensed as an agent for the above company in Wisconsin under
National Producer Number _____ for the year _____, and appointed as attorney-in-fact
with authority to execute this payment and performance bond which power of attorney has not been
revoked.

Date

Agent Signature

SECTION J: PREVAILING WAGE RATES

ISSUE DATE: 1/8/2016

PROJECT:

ALL PUBLIC WORKS PROJECTS UNDER SEC. 66.0903, STATS-CITY OF MADISON
MADISON CITY, DANE COUNTY, WI
Determination No. 201600001

PROJECT OWNER:

ROBERT F PHILLIPS, INTERIM CITY ENGINEER
CITY OF MADISON - ENGINEERING
210 M L KING JR BLVD, RM 115
MADISON, WI 537033342

REQUESTER:

ROBERT F PHILLIPS, INTERIM CITY ENGINEER
CITY OF MADISON - ENGINEERING
210 M L KING JR BLVD, RM 115
MADISON, WI 537033342

ADDITIONAL CONTACT:

NORMAN DAVIS, CONTRACT COMPLIANCE
CITY OF MADISON-DEPT OF CIVIL RTS-AA DIV
210 MARTIN L KING JR BLVD, RM 523
MADISON, WI 537033342

The department received an application for prevailing wage rate determination for the above-captioned project. The department conducted a survey to determine the prevailing wage rate for the trade(s) or occupation(s) needed to complete the project. The survey's findings appear in the attached project determination.

If you believe that the wage rate for any trade or occupation does not accurately reflect the prevailing wage rate in the city, village or town where the project is located, you may ask the department to conduct an administrative review of such wage rate. You must submit this request in writing within 30 days from the date indicated above. Additionally, your request must include wage rate information from at least three similar projects in the city, village or town where the proposed project is located and on which some work has been performed by the contested trade(s) during the current survey period and was previously considered by the department in issuing the attached determination. See DWD 290.10 of the Wisconsin Administrative Code and either s. 66.0903(3)(br), Stats., or s. 103.49(3)(c), Stats., for a complete explanation of the administrative review process.

Enclosures

It is hereby ordered that the prevailing wage rates set forth in the attached project determination shall only be applicable to the above referenced project. This order is a **FINAL ORDER** of the department unless a timely request for an administrative review is filed with the department.

ISSUED BY:

Equal Rights Division
Labor Standards Bureau
Construction Wage Standards Section
P.O. Box 8928, Madison, WI 53708-8928
(608)266-6861

Web Site: <http://dwd.wisconsin.gov/er/>

PREVAILING WAGE RATE DETERMINATION

Issued by the State of Wisconsin
Department of Workforce Development
Pursuant to s. 66.0903, Wis. Stats.
Issued On: 1/8/2016

DETERMINATION NUMBER: 201600001

EXPIRATION DATE: Prime Contracts MUST Be Awarded or Negotiated On Or Before 12/31/2016. If NOT, You MUST Reapply.

PROJECT NAME: ALL PUBLIC WORKS PROJECTS UNDER SEC. 66.0903, STATS-CITY OF MADISON

PROJECT LOCATION: MADISON CITY, DANE COUNTY, WI

CONTRACTING AGENCY: CITY OF MADISON - ENGINEERING

CLASSIFICATION:	Contractors are responsible for correctly classifying their workers. Either call the Department of Workforce Development (DWD) with trade or classification questions or consult DWD's Dictionary of Occupational Classifications & Work Descriptions on the DWD website at: dwd.wisconsin.gov/er/prevailing_wage_rate/Dictionary/dictionary_main.htm .
OVERTIME:	<p>Time and one-half must be paid for all hours worked:</p> <ul style="list-style-type: none">- over 10 hours per day on prevailing wage projects- over 40 hours per calendar week- Saturday and Sunday- on all of the following holidays: January 1; the last Monday in May; July 4; the 1st Monday in September; the 4th Thursday in November; December 25;- The day before if January 1, July 4 or December 25 falls on a Saturday;- The day following if January 1, July 4 or December 25 falls on a Sunday. <p>Apply the time and one-half overtime calculation to whichever is higher between the Hourly Basic Rate listed on this project determination or the employee's regular hourly rate of pay. Add any applicable Premium or DOT Premium to the Hourly Basic Rate before calculating overtime.</p> <p>A DOT Premium (discussed below) may supersede this time and one-half requirement.</p>
FUTURE INCREASE:	When a specific trade or occupation requires a future increase, you MUST add the full hourly increase to the "TOTAL" on the effective date(s) indicated for the specific trade or occupation.
PREMIUM PAY:	If indicated for a specific trade or occupation, the full amount of such pay MUST be added to the "HOURLY BASIC RATE OF PAY" indicated for such trade or occupation, whenever such pay is applicable.
DOT PREMIUM:	This premium only applies to highway and bridge projects owned by the Wisconsin Department of Transportation and to the project type heading "Airport Pavement or State Highway Construction." DO NOT apply the premium calculation under any other project type on this determination.
APPRENTICES:	Pay apprentices a percentage of the applicable journey person's hourly basic rate of pay and hourly fringe benefit contributions specified in this determination. Obtain the appropriate percentage from each apprentice's contract or indenture.
SUBJOURNEY:	Subjourney wage rates may be available for some of the trades or occupations indicated below with the exception of laborers, truck drivers and heavy equipment operators. Any employer interested in using a subjourney classification on this project MUST complete Form ERD-10880 and request the applicable wage rate from the Department of Workforce Development PRIOR to using the subjourney worker on this project.

This document **MUST BE POSTED** by the **CONTRACTING AGENCY** in at least one conspicuous and easily accessible place **on the site of the project**. A local governmental unit may post this document at the place normally used to post public notices if there is no common site on the project. This document **MUST** remain posted during the entire time any worker is employed on the project and **MUST** be physically incorporated into the specifications and all contracts and subcontracts. If you have any questions, please write to the Equal Rights Division, Labor Standards Bureau, P.O. Box 8928, Madison, Wisconsin 53708 or call (608) 266-6861.

The following statutory provisions apply to local governmental unit projects of public works and are set forth below pursuant to the requirements of s. 66.0903(8), Stats.

s. 66.0903 (1) (f) & s. 103.49 (1) (c) "PREVAILING HOURS OF LABOR" for any trade or occupation in any area means 10 hours per day and 40 hours per week and may not include any hours worked on a Saturday or Sunday or on any of the following holidays:

1. January 1.
2. The last Monday in May.
3. July 4.
4. The first Monday in September.
5. The 4th Thursday in November.
6. December 25.
7. The day before if January 1, July 4 or December 25 falls on a Saturday.
8. The day following if January 1, July 4 or December 25 falls on a Sunday.

s. 66.0903 (10) RECORDS; INSPECTION; ENFORCEMENT.

(a) Each contractor, subcontractor, or contractor's or subcontractor's agent performing work on a project of public works that is subject to this section shall keep full and accurate records clearly indicating the name and trade or occupation of every person performing the work described in sub. (4) and an accurate record of the number of hours worked by each of those persons and the actual wages paid for the hours worked.

s. 66.0903 (11) LIABILITY AND PENALTIES.

(a) 1. Any contractor, subcontractor, or contractor's or subcontractor's agent who fails to pay the prevailing wage rate determined by the department under sub. (3) or who pays less than 1.5 times the hourly basic rate of pay for all hours worked in excess of the prevailing hours of labor is liable to any affected employee in the amount of his or her unpaid wages or his or her unpaid overtime compensation and in an additional amount as liquidated damages as provided under subd. 2., 3., whichever is applicable.

2. If the department determines upon inspection under sub. (10) (b) or (c) that a contractor, subcontractor, or contractor's or subcontractor's agent has failed to pay the prevailing wage rate determined by the department under sub. (3) or has paid less than 1.5 times the hourly basic rate of pay for all hours worked in excess of the prevailing hours of labor, the department shall order the contractor to pay to any affected employee the amount of his or her unpaid wages or his or her unpaid overtime compensation and an additional amount equal to 100 percent of the amount of those unpaid wages or that unpaid overtime compensation as liquidated damages within a period specified by the department in the order.

3. In addition to or in lieu of recovering the liability specified in subd. 1. as provided in subd. 2., any employee for and in behalf of that employee and other employees similarly situated may commence an action to recover that liability in any court of competent jurisdiction. If the court finds that a contractor, subcontractor, or contractor's or subcontractor's agent has failed to pay the prevailing wage rate determined by the department under sub. (3) or has paid less than 1.5 times the hourly basic rate of pay for all hours worked in excess of the prevailing hours of labor, the court shall order the contractor, subcontractor, or agent to pay to any affected employee the amount of his or her unpaid wages or his or her unpaid overtime compensation and an additional amount equal to 100 percent of the amount of those unpaid wages or that unpaid overtime compensation as liquidated damages.

5. No employee may be a party plaintiff to an action under subd. 3. unless the employee consents in writing to become a party and the consent is filed in the court in which the action is brought. Notwithstanding s. 814.04 (1), the court shall, in addition to any judgment awarded to the plaintiff, allow reasonable attorney fees and costs to be paid by the defendant.

BUILDING OR HEAVY CONSTRUCTION

Includes sheltered enclosures with walk-in access for the purpose of housing persons, employees, machinery, equipment or supplies and non-sheltered work such as canals, dams, dikes, reservoirs, storage tanks, etc. A sheltered enclosure need not be "habitable" in order to be considered a building. The installation of machinery and/or equipment, both above and below grade level, does not change a project's character as a building. On-site grading, utility work and landscaping are included within this definition. Residential buildings of four (4) stories or less, agricultural buildings, parking lots and driveways are NOT included within this definition.

SKILLED TRADES

Fringe Benefits Must Be Paid On <u>All</u> Hours Worked		HOURLY BASIC RATE OF PAY	HOURLY FRINGE BENEFITS	TOTAL
CODE	TRADE OR OCCUPATION	\$	\$	\$
101	Acoustic Ceiling Tile Installer Future Increase(s): Add \$1.42/hr on 6/1/2016.	33.02	17.12	50.14
102	Boilermaker	33.35	28.29	61.64
103	Bricklayer, Blocklayer or Stonemason Future Increase(s): Add \$1.45 on 06/06/2016 Premium Increase(s): DOT PREMIUM: Pay two times the hourly basic rate on Sunday, New Year's Day, Memorial Day, Independence Day, Labor Day, Thanksgiving Day & Christmas Day.	32.86	20.03	52.89
104	Cabinet Installer Future Increase(s): Add \$1.42/hr on 6/1/2016.	33.02	17.12	50.14
105	Carpenter Future Increase(s): Add \$1.42/hr on 6/1/2016. Premium Increase(s): DOT PREMIUM: Pay two times the hourly basic rate on Sunday, New Year's Day, Memorial Day, Independence Day, Labor Day, Thanksgiving Day & Christmas Day.	33.02	17.12	50.14
106	Carpet Layer or Soft Floor Coverer Future Increase(s): Add \$1.42/hr on 6/1/2016.	33.02	17.12	50.14
107	Cement Finisher	33.15	16.40	49.55
108	Drywall Taper or Finisher	29.97	20.08	50.05
109	Electrician Future Increase(s): Add \$1.25/hr on 6/1/16. Premium Increase(s): DOT PREMIUM: Pay two times the hourly basic rate on Sunday, New Year's Day, Memorial Day, Independence Day, Labor Day, Thanksgiving Day & Christmas Day.	35.75	19.97	55.72
110	Elevator Constructor	46.05	27.09	73.14
111	Fence Erector	18.72	5.78	24.50

Fringe Benefits Must Be Paid On <u>All</u> Hours Worked		HOURLY BASIC RATE OF PAY	HOURLY FRINGE BENEFITS	TOTAL
CODE	TRADE OR OCCUPATION	\$	\$	\$
112	Fire Sprinkler Fitter	36.78	19.97	56.75
113	Glazier	38.27	14.42	52.69
114	Heat or Frost Insulator	33.53	27.31	60.84
115	Insulator (Batt or Blown) Future Increase(s): Add \$1.42/hr on 6/1/2016.	33.02	17.12	50.14
116	Ironworker	32.50	20.58	53.08
117	Lather	32.72	16.00	48.72
118	Line Constructor (Electrical)	40.81	18.06	58.87
119	Marble Finisher	25.72	18.54	44.26
120	Marble Mason	32.82	18.67	51.49
121	Metal Building Erector	22.40	6.27	28.67
122	Millwright	34.44	16.05	50.49
123	Overhead Door Installer	31.93	13.39	45.32
124	Painter	26.70	16.65	43.35
125	Pavement Marking Operator	30.00	18.81	48.81
126	Piledriver Future Increase(s): Add \$1.44/hr on 6/1/2016. Premium Increase(s): DOT PREMIUM: Pay two times the hourly basic rate on Sunday, New Year's Day, Memorial Day, Independence Day, Labor Day, Thanksgiving Day & Christmas Day.	33.56	17.12	50.68
127	Pipeline Fuser or Welder (Gas or Utility)	44.20	18.26	62.46
129	Plasterer	32.82	18.81	51.63
130	Plumber	38.82	18.02	56.84
132	Refrigeration Mechanic	45.55	18.71	64.26
133	Roofer or Waterproofer	29.65	1.71	31.36
134	Sheet Metal Worker	35.55	24.67	60.22
135	Steamfitter	45.55	18.71	64.26
137	Teledata Technician or Installer	22.50	12.74	35.24
138	Temperature Control Installer	34.97	19.67	54.64
139	Terrazzo Finisher	25.72	18.54	44.26

Fringe Benefits Must Be Paid On <u>All</u> Hours Worked		HOURLY BASIC RATE OF PAY	HOURLY FRINGE BENEFITS	TOTAL
CODE	TRADE OR OCCUPATION	\$	\$	\$
140	Terrazzo Mechanic Future Increase(s): Add \$1.60 on 06/06/2016	33.98	18.96	52.94
141	Tile Finisher	30.00	0.00	30.00
142	Tile Setter Future Increase(s): Add \$1.45/hr on 6/06/2016.	31.59	19.61	51.20
143	Tuckpointer, Caulker or Cleaner Future Increase(s): Add \$1.45 on 06/06/2016 Premium Increase(s): DOT PREMIUM: Pay two times the hourly basic rate on Sunday, New Year's Day, Memorial Day, Independence Day, Labor Day, Thanksgiving Day & Christmas Day.	32.86	20.03	52.89
144	Underwater Diver (Except on Great Lakes)	36.74	16.00	52.74
146	Well Driller or Pump Installer Future Increase(s): Add \$1/hr on 6/1/2016; Add \$1/hr on 6/1/2017.	25.32	16.40	41.72
147	Siding Installer	17.00	6.71	23.71
150	Heavy Equipment Operator - ELECTRICAL LINE CONSTRUCTION ONLY	36.73	20.41	57.14
151	Light Equipment Operator -ELECTRICAL LINE CONSTRUCTION ONLY	32.65	15.52	48.17
152	Heavy Truck Driver - ELECTRICAL LINE CONSTRUCTION ONLY	28.57	13.71	42.28
153	Light Truck Driver - ELECTRICAL LINE CONSTRUCTION ONLY	26.53	13.55	40.08
154	Groundman - ELECTRICAL LINE CONSTRUCTION ONLY	25.00	12.55	37.55

TRUCK DRIVERS

Fringe Benefits Must Be Paid On <u>All</u> Hours Worked		HOURLY BASIC RATE OF PAY	HOURLY FRINGE BENEFITS	TOTAL
CODE	TRADE OR OCCUPATION	\$	\$	\$
201	Single Axle or Two Axle	33.69	19.78	53.47
203	Three or More Axle	18.25	21.61	39.86
204	Articulated, Euclid, Dumptor, Off Road Material Hauler Future Increase(s): Add \$1.60/hr on 6/3/2016.	34.69	20.38	55.07
205	Pavement Marking Vehicle	18.25	21.61	39.86
207	Truck Mechanic	18.25	21.61	39.86

LABORERS

Fringe Benefits Must Be Paid On <u>All</u> Hours Worked		HOURLY BASIC RATE OF PAY	HOURLY FRINGE BENEFITS	TOTAL
CODE	TRADE OR OCCUPATION	\$	\$	\$
301	General Laborer Future Increase(s): Add \$1.25/hr eff. 06/06/2016 Premium Increase(s): Add \$1.00/hr for certified welder and pipelayer; Add \$.25/hr for mason tender.	25.81	15.63	41.44
302	Asbestos Abatement Worker	17.00	4.22	21.22
303	Landscaper	21.90	9.83	31.73
310	Gas or Utility Pipeline Laborer (Other Than Sewer and Water)	20.83	18.39	39.22
311	Fiber Optic Laborer (Outside, Other Than Concrete Encased)	19.35	0.00	19.35
314	Railroad Track Laborer	17.00	3.96	20.96
315	Final Construction Clean-Up Worker	29.01	7.20	36.21

**HEAVY EQUIPMENT OPERATORS
SITE PREPARATION, UTILITY OR LANDSCAPING WORK ONLY**

Fringe Benefits Must Be Paid On <u>All</u> Hours Worked		HOURLY BASIC RATE OF PAY	HOURLY FRINGE BENEFITS	TOTAL
CODE	TRADE OR OCCUPATION	\$	\$	\$
501	Air Track, Rotary or Percussion Drilling Machine &/or Hammers, Blaster; Asphalt Milling Machine; Boring Machine (Directional, Horizontal or Vertical); Backhoe (Track Type) Having a Mfgr's Rated Capacity of 130,000 Lbs. or Over; Backhoe (Track Type) Having a Mfgr's Rated Capacity of Under 130,000 Lbs., Backhoe (Mini, 15,000 Lbs. & Under); Bulldozer or Endloader (Over 40 hp); Compactor (Self-Propelled 85 Ft Total Drum Width & Over, or Tractor Mounted, Towed & Light Equipment); Concrete Batch Plant, Batch Hopper; Concrete Breaker (Large, Auto, Vibratory/Sonic, Manual or Remote); Crane, Shovel, Dragline, Clamshells; Forklift (Machinery Moving or Steel Erection, 25 Ft & Over); Gradall (Cruz-Aire Type); Grader or Motor Patrol; Master Mechanic; Mechanic or Welder; Robotic Tool Carrier (With or Without Attachments); Scraper (Self Propelled or Tractor Drawn) 5 cu yds or More Capacity; Tractor or Truck Mounted Hydraulic Backhoe; Tractor or Truck Mounted Hydraulic Crane (10 Tons or Under); Tractor (Scraper, Dozer, Pusher, Loader); Trencher (Wheel Type or Chain Type Having Over 8 Inch Bucket). Future Increase(s): Add \$1.60/hr on 6/3/2016.	35.22	20.38	55.60
502	Backfiller; Broom or Sweeper; Bulldozer or Endloader (Under 40 hp); Environmental Burner; Forestry Equipment, Timbco, Tree Shear, Tub Grinder, Processor; Jeep Digger; Screed (Milling Machine); Skid Rig; Straddle Carrier or Travel Lift; Stump Chipper; Trencher (Wheel Type or Chain Type Having 8 Inch Bucket & Under). Future Increase(s): Add \$1.60/hr on 6/3/2016.	34.69	20.38	55.07

Fringe Benefits Must Be Paid On <u>All</u> Hours Worked		HOURLY BASIC RATE OF PAY	HOURLY FRINGE BENEFITS	TOTAL
CODE	TRADE OR OCCUPATION	\$	\$	\$
503	Air Compressor (&/or 400 CFM or Over); Augers (Vertical & Horizontal); Compactor (Self-Propelled 84 Ft Total Drum Width & Under, or Tractor Mounted, Towed & Light Equipment); Crusher, Screening or Wash Plant; Farm or Industrial Type Tractor; Forklift; Generator (&/or 150 KW or Over); Greaser; High Pressure Utility Locating Machine (Daylighting Machine); Mulcher; Oiler; Post Hole Digger or Driver; Pump (3 Inch or Over) or Well Points; Refrigeration Plant or Freeze Machine; Rock, Stone Breaker; Skid Steer Loader (With or Without Attachments); Vibratory Hammer or Extractor, Power Pack. Future Increase(s): Add \$1.60/hr on 6/3/2016.	32.62	20.38	53.00
504	Work Performed on the Great Lakes Including Diver; Wet Tender or Hydraulic Dredge Engineer.	41.65	21.71	63.36
505	Work Performed on the Great Lakes Including Crane or Backhoe Operator; Assistant Hydraulic Dredge Engineer; Hydraulic Dredge Leverman or Diver's Tender; Mechanic or Welder; 70 Ton & Over Tug Operator. Future Increase(s): Add \$1.25/hr on 1/1/2017. Premium Increase(s): Add \$.50/hr for Friction Crane, Lattice Boom or Crane Certification (CCO).	44.05	23.24	67.29
506	Work Performed on the Great Lakes Including Deck Equipment Operator or Machineryman (Maintains Cranes Over 50 Tons or Backhoes 115,000 Lbs. or More); Tug, Launch or Loader, Dozer or Like Equipment When Operated on a Barge, Breakwater Wall, Slip, Dock or Scow, Deck Machinery. Future Increase(s): Add \$1.25/hr on 1/1/2017.	39.20	23.09	62.29
507	Work Performed on the Great Lakes Including Deck Equipment Operator, Machineryman or Fireman (Operates 4 Units or More or Maintains Cranes 50 Tons or Under or Backhoes 115,000 Lbs. or Under); Deck Hand, Deck Engineer or Assistant Tug Operator; Off Road Trucks - Great Lakes ONLY.	36.72	21.15	57.87

**HEAVY EQUIPMENT OPERATORS
EXCLUDING SITE PREPARATION, UTILITY, PAVING LANDSCAPING WORK**

Fringe Benefits Must Be Paid On <u>All</u> Hours Worked		HOURLY BASIC RATE OF PAY	HOURLY FRINGE BENEFITS	TOTAL
CODE	TRADE OR OCCUPATION	\$	\$	\$
508	Boring Machine (Directional); Crane, Tower Crane, Pedestal Tower or Derrick, With or Without Attachments, With a Lifting Capacity of Over 100 Tons, Self-Erecting Tower Crane With a Lifting Capacity of Over 4,000 Lbs., Crane With Boom Dollies; Crane, Tower Crane, Pedestal Tower or Derrick, With Boom, Leads &/or Jib Lengths Measuring 176 Ft or Over; Master Mechanic. Future Increase(s): Add \$1.60/hr on 6/3/2016. Premium Increase(s):	37.67	20.38	58.05

Fringe Benefits Must Be Paid On <u>All</u> Hours Worked		HOURLY BASIC RATE OF PAY	HOURLY FRINGE BENEFITS	TOTAL
CODE	TRADE OR OCCUPATION	\$	\$	\$
	Add \$.50/hr for >200 Ton; Add \$1/hr at 300 Ton; Add \$1.50/hr at 400 Ton; Add \$2/hr at 500 Ton & Over.			
509	Backhoe (Track Type) Having a Mfgr's Rated Capacity of 130,000 Lbs. or Over; Boring Machine (Horizontal or Vertical); Caisson Rig; Crane, Tower Crane, Portable Tower, Pedestal Tower or Derrick, With or Without Attachments, With a Lifting Capacity of 100 Tons or Under, Self-Erecting Tower Crane With A Lifting Capacity Of 4,000 Lbs. & Under; Crane, Tower Crane, Portable Tower, Pedestal Tower or Derrick, With Boom, Leads &/or Jib Lengths Measuring 175 Ft or Under; Pile Driver; Versi Lifts, Tri-Lifts & Gantrys (20,000 Lbs. & Over). Future Increase(s): Add \$1.60/hr on 6/3/2016. Premium Increase(s): Add \$.25/hr for all >45 Ton lifting capacity cranes.	36.42	20.38	56.80
510	Backhoe (Track Type) Having a Mfgr.'s Rated Capacity of Under 130,000 Lbs., Backhoe (Mini, 15,000 Lbs. & Under); Concrete Bump Cutter, Grinder, Planing or Grooving Machine; Concrete Laser/Screed; Concrete Paver (Slipform); Concrete Pump (Over 46 Meter), Concrete Conveyor (Rotec or Bidwell Type); Concrete Slipform Placer Curb & Gutter Machine; Concrete Spreader & Distributor; Dredge (NOT Performing Work on the Great Lakes); Forklift (Machinery Moving or Steel Erection, 25 Ft & Over); Gradall (Cruz-Aire Type); Hydro-Blaster (10,000 PSI or Over); Milling Machine; Skid Rig; Traveling Crane (Bridge Type). Future Increase(s): Add \$1.60/hr on 6/3/2016.	35.22	20.38	55.60
511	Air, Track, Rotary or Percussion Drilling Machine &/or Hammers, Blaster; Bulldozer or Endloader (Over 40 hp); Compactor (Self-Propelled 85 Ft Total Drum Width & Over, or Tractor Mounted, Towed & Light Equipment); Concrete Pump (46 Meter & Under), Concrete Conveyor (Rotec or Bidwell Type); Crane (Carry Deck, Mini) or Truck Mounted Hydraulic Crane (10 Tons or Under); Environmental Burner; Gantrys (Under 20,000 Lbs.); Grader or Motor Patrol; High Pressure Utility Locating Machine (Daylighting Machine); Manhoist; Material or Stack Hoist; Mechanic or Welder; Railroad Track Rail Leveling Machine, Tie Placer, Extractor, Tamper, Stone Leveler or Rehabilitation Equipment; Roller (Over 5 Ton); Scraper (Self Propelled or Tractor Drawn) 5 cu yd or More Capacity; Screed (Milling Machine); Sideboom; Straddle Carrier or Travel Lift; Tining or Curing Machine; Tractor (Scraper, Dozer, Pusher, Loader); Tractor or Truck Mounted Hydraulic Backhoe; Tractor or Truck Mounted Hydraulic Crane (10 Tons or Under); Trencher (Wheel Type or Chain Type Having Over 8-Inch Bucket). Future Increase(s): Add \$1.60/hr on 6/3/2016.	34.69	20.38	55.07

Fringe Benefits Must Be Paid On <u>All</u> Hours Worked		HOURLY BASIC RATE OF PAY	HOURLY FRINGE BENEFITS	TOTAL
CODE	TRADE OR OCCUPATION	\$	\$	\$
512	Backfiller; Broom or Sweeper; Bulldozer or Endloader (Under 40 hp); Compactor (Self-Propelled 84 Ft Total Drum Width & Under, or Tractor Mounted, Towed & Light Equipment); Concrete Batch Plant, Batch Hopper; Concrete Breaker (Large, Auto, Vibratory/Sonic, Manual or Remote); Concrete Conveyor System; Concrete Finishing Machine (Road Type); Fireman (Pile Driver & Derrick NOT Performing Work on the Great Lakes); Grout Pump; Hoist (Tugger, Automatic); Industrial Locomotives; Jeep Digger; Lift Slab Machine; Mulcher; Roller (Rubber Tire, 5 Ton or Under); Screw or Gypsum Pumps; Stabilizing or Concrete Mixer (Self-Propelled or 14S or Over); Stump Chipper; Trencher (Wheel Type or Chain Type Having 8-Inch Bucket & Under); Winches & A-Frames. Future Increase(s): Add \$1.60/hr on 6/3/2016.	32.62	20.38	53.00
513	Air Compressor (&/or 400 CFM or Over); Air, Electric or Hydraulic Jacking System; Augers (Vertical & Horizontal); Boatmen (NOT Performing Work on the Great Lakes); Boiler (Temporary Heat); Crusher, Screening or Wash Plant; Elevator; Farm or Industrial Type Tractor; Fireman (Asphalt Plant NOT Performing Work on the Great Lakes); Forklift; Generator (&/or 150 KW or Over); Greaser; Heaters (Mechanical); Loading Machine (Conveyor); Oiler; Post Hole Digger or Driver; Prestress Machine; Pump (3 Inch or Over) or Well Points; Refrigeration Plant or Freeze Machine; Robotic Tool Carrier (With or Without Attachments); Rock, Stone Breaker; Skid Steer Loader (With or Without Attachments); Vibratory Hammer or Extractor, Power Pack. Future Increase(s): Add \$1.60/hr on 6/3/2016.	31.99	20.38	52.37
514	Gas or Utility Pipeline, Except Sewer & Water (Primary Equipment). Future Increase(s): Add \$1/hr on 5/30/2016.	37.04	22.44	59.48
515	Gas or Utility Pipeline, Except Sewer & Water (Secondary Equipment).	33.82	20.30	54.12
516	Fiber Optic Cable Equipment	29.50	0.68	30.18

SEWER, WATER OR TUNNEL CONSTRUCTION
--

Includes those projects that primarily involve public sewer or water distribution, transmission or collection systems and related tunnel work (excluding buildings).

SKILLED TRADES

CODE	TRADE OR OCCUPATION	FRINGE BENEFITS MUST BE PAID ON <u>All</u> Hours Worked	HOURLY BASIC RATE OF PAY	HOURLY FRINGE BENEFITS	TOTAL
			\$	\$	\$
103	Bricklayer, Blocklayer or Stonemason		32.82	18.67	51.49
105	Carpenter		32.72	16.00	48.72
107	Cement Finisher Future Increase(s): Add \$1.75 on 6/1/16. Premium Increase(s): DOT PREMIUMS: 1) Pay two times the hourly basic rate on Sunday, New Year's Day, Memorial Day, Independence Day, Labor Day, Thanksgiving Day & Christmas Day. 2) Add \$1.40/hr when the Wisconsin Department of Transportation or responsible governing agency requires that work be performed at night under artificial illumination with traffic control and the work is completed after sunset and before sunrise.		35.97	17.85	53.82
109	Electrician		52.00	1.50	53.50
111	Fence Erector		18.72	5.78	24.50
116	Ironworker		32.50	20.58	53.08
118	Line Constructor (Electrical)		40.81	18.06	58.87
125	Pavement Marking Operator		30.00	18.81	48.81
126	Piledriver		33.24	16.00	49.24
130	Plumber Future Increase(s): Add \$1.50 on 6/1/16		39.95	19.45	59.40
135	Steamfitter		44.20	18.26	62.46
137	Teledata Technician or Installer		22.50	12.74	35.24
143	Tuckpointer, Caulker or Cleaner		32.82	18.67	51.49
144	Underwater Diver (Except on Great Lakes)		31.00	20.43	51.43
146	Well Driller or Pump Installer Future Increase(s): Add \$1/hr on 6/1/2016; Add \$1/hr on 6/1/2017.		25.32	16.40	41.72
150	Heavy Equipment Operator - ELECTRICAL LINE CONSTRUCTION ONLY		36.73	15.92	52.65
151	Light Equipment Operator -ELECTRICAL LINE CONSTRUCTION ONLY		32.65	15.52	48.17

Fringe Benefits Must Be Paid On <u>All</u> Hours Worked		HOURLY BASIC RATE OF PAY	HOURLY FRINGE BENEFITS	TOTAL
CODE	TRADE OR OCCUPATION	\$	\$	\$
152	Heavy Truck Driver - ELECTRICAL LINE CONSTRUCTION ONLY	28.57	13.71	42.28
153	Light Truck Driver - ELECTRICAL LINE CONSTRUCTION ONLY	26.53	13.55	40.08
154	Groundman - ELECTRICAL LINE CONSTRUCTION ONLY	21.75	12.97	34.72

TRUCK DRIVERS

Fringe Benefits Must Be Paid On <u>All</u> Hours Worked		HOURLY BASIC RATE OF PAY	HOURLY FRINGE BENEFITS	TOTAL
CODE	TRADE OR OCCUPATION	\$	\$	\$
201	Single Axle or Two Axle	19.00	0.00	19.00
203	Three or More Axle	19.00	0.00	19.00
204	Articulated, Euclid, Dumptor, Off Road Material Hauler	33.69	19.78	53.47
205	Pavement Marking Vehicle	19.00	0.00	19.00
207	Truck Mechanic	19.00	0.00	19.00

LABORERS

Fringe Benefits Must Be Paid On <u>All</u> Hours Worked		HOURLY BASIC RATE OF PAY	HOURLY FRINGE BENEFITS	TOTAL
CODE	TRADE OR OCCUPATION	\$	\$	\$
301	General Laborer Future Increase(s): Add \$1.25/hr eff. 06/06/2016 Premium Increase(s): Add \$.20 for blaster, bracer, manhole builder, caulker, bottomman and power tool; Add \$.55 for pipelayer; Add \$1.00 for tunnel work 0-15 lbs. compressed air; Add \$2.00 for over 15-30 lbs. compressed air; Add \$3.00 for over 30 lbs. compressed air.	27.18	15.64	42.82
303	Landscaper	41.00	0.00	41.00
304	Flagperson or Traffic Control Person	20.92	14.80	35.72
311	Fiber Optic Laborer (Outside, Other Than Concrete Encased)	19.35	0.00	19.35
314	Railroad Track Laborer	17.00	3.96	20.96

**HEAVY EQUIPMENT OPERATORS
SEWER, WATER OR TUNNEL WORK**

Fringe Benefits Must Be Paid On <u>All</u> Hours Worked		HOURLY BASIC RATE OF PAY	HOURLY FRINGE BENEFITS	TOTAL
CODE	TRADE OR OCCUPATION	\$	\$	\$
521	Backhoe (Track Type) Having a Mfgr.'s Rated Capacity of 130,000 Lbs. or Over; Caisson Rig; Crane, Tower Crane, Pedestal Tower or Derrick, With Boom, Leads &/or Jib Lengths Measuring 176 Ft or Over; Crane, Tower Crane, Pedestal Tower or Derrick, With or Without Attachments, With a Lifting Capacity of Over 100 Tons, Self-Erecting Tower Crane With a Lifting Capacity Of Over 4,000 Lbs., Crane With Boom Dollies; Master Mechanic; Pile Driver. Premium Increase(s): Add \$.25/hr for operating tower crane.	38.09	20.80	58.89
522	Backhoe (Track Type) Having a Mfgr.'s Rated Capacity of Under 130,000 Lbs., Backhoe (Mini, 15,000 Lbs. & Under); Boring Machine (Directional); Concrete Bump Cutter, Grinder, Planing or Grooving Machine; Concrete Laser/Screed; Concrete Paver (Slipform); Concrete Pump (Over 46 Meter), Concrete Conveyor (Rotec or Bidwell Type); Concrete Spreader & Distributor; Crane, Tower Crane, Portable Tower, Pedestal Tower or Derrick, With Boom, Leads &/or Jib Lengths Measuring 175 Ft or Under; Crane, Tower Crane, Portable Tower, Pedestal Tower or Derrick, With or Without Attachments, With a Lifting Capacity of 100 Tons or Under, Self-Erecting Tower Crane With a Lifting Capacity of 4,000 Lbs. & Under; Dredge (NOT Performing Work on the Great Lakes); Milling Machine; Skid Rig; Telehandler; Traveling Crane (Bridge Type). Future Increase(s): Add \$1.60/hr on 6/3/2016.	35.22	20.38	55.60
523	Air Track, Rotary or Percussion Drilling Machine &/or Hammers, Blaster; Boring Machine (Horizontal or Vertical); Bulldozer or Endloader (Over 40 hp); Crane (Carry Deck, Mini) or Truck Mounted Hydraulic Crane (10 Tons or Under); Concrete Pump (46 Meter & Under), Concrete Conveyor (Rotec or Bidwell Type); Concrete Slipform Placer Curb & Gutter Machine; Gradall (Cruz-Aire Type); Grader or Motor Patrol; Hydro-Blaster (10,000 PSI or Over); Manhoist; Material or Stack Hoist; Mechanic or Welder; Roller (Over 5 Ton); Scraper (Self Propelled or Tractor Drawn) 5 cu yd or More Capacity; Screed (Milling Machine); Sideboom; Straddle Carrier or Travel Lift; Tractor (Scraper, Dozer, Pusher, Loader); Tractor or Truck Mounted Hydraulic Backhoe; Tractor or Truck Mounted Hydraulic Crane (10 Tons or Under); Trencher (Wheel Type or Chain Type Having Over 8-Inch Bucket). Future Increase(s): Add \$1.60/hr on 6/3/2016.	34.69	20.38	55.07

Fringe Benefits Must Be Paid On <u>All</u> Hours Worked		HOURLY BASIC RATE OF PAY	HOURLY FRINGE BENEFITS	TOTAL
CODE	TRADE OR OCCUPATION	\$	\$	\$
524	Backfiller; Broom or Sweeper; Bulldozer or Endloader (Under 40 hp); Compactor (Self-Propelled 85 Ft Total Drum Width & Over, or Tractor Mounted, Towed & Light Equipment); Concrete Batch Plant, Batch Hopper; Concrete Breaker (Large, Auto, Vibratory/Sonic, Manual or Remote); Concrete Conveyor System; Concrete Finishing Machine (Road Type); Environmental Burner; Fireman (Pile Driver & Derrick NOT Performing Work on the Great Lakes); Forestry Equipment, Timbco, Tree Shear, Tub Grinder, Processor; Hoist (Tugger, Automatic); Grout Pump; Jeep Digger; Lift Slab Machine; Mulcher; Power Subgrader; Pump (3 Inch or Over) or Well Points; Robotic Tool Carrier (With or Without Attachments); Roller (Rubber Tire, 5 Ton or Under); Screw or Gypsum Pumps; Stabilizing or Concrete Mixer (Self-Propelled or 14S or Over); Stump Chipper; Tining or Curing Machine; Trencher (Wheel Type or Chain Type Having 8-Inch Bucket & Under); Winches & A-Frames.	33.69	21.75	55.44
525	Air Compressor (&/or 400 CFM or Over); Air, Electric or Hydraulic Jacking System; Augers (Vertical & Horizontal); Compactor (Self-Propelled 84 Ft Total Drum Width & Under, or Tractor Mounted, Towed & Light Equipment); Crusher, Screening or Wash Plant; Farm or Industrial Type Tractor; Fireman (Asphalt Plant NOT Performing Work on the Great Lakes); Generator (&/or 150 KW or Over); Heaters (Mechanical); High Pressure Utility Locating Machine (Daylighting Machine); Loading Machine (Conveyor); Post Hole Digger or Driver; Refrigeration Plant or Freeze Machine; Rock, Stone Breaker; Skid Steer Loader (With or Without Attachments); Vibratory Hammer or Extractor, Power Pack. Future Increase(s): Add \$1.60/hr on 6/3/2016.	31.99	20.38	52.37
526	Boiler (Temporary Heat); Forklift; Greaser; Oiler.	30.99	19.78	50.77
527	Work Performed on the Great Lakes Including Diver; Wet Tender or Hydraulic Dredge Engineer.	41.65	21.71	63.36
528	Work Performed on the Great Lakes Including 70 Ton & Over Tug Operator; Assistant Hydraulic Dredge Engineer; Crane or Backhoe Operator; Hydraulic Dredge Leverman or Diver's Tender; Mechanic or Welder.	41.65	21.71	63.36
529	Work Performed on the Great Lakes Including Deck Equipment Operator or Machineryman (Maintains Cranes Over 50 Tons or Backhoes 115,000 Lbs. or More); Tug, Launch or Loader, Dozer or Like Equipment When Operated on a Barge, Breakwater Wall, Slip, Dock or Scow, Deck Machinery.	36.72	21.15	57.87
530	Work Performed on the Great Lakes Including Deck Equipment Operator; Machineryman or Fireman (Operates 4 Units or More or Maintains Cranes 50 Tons or Under or Backhoes 115,000 Lbs. or Under), Deck Hand, Deck Engineer or Assistant Tug Operator; Off Road Trucks - Great Lakes ONLY.	36.72	21.15	57.87

AIRPORT PAVEMENT OR STATE HIGHWAY CONSTRUCTION

Includes all airport projects (excluding buildings) and all projects awarded by the Wisconsin Department of Transportation (excluding buildings).

SKILLED TRADES

CODE	TRADE OR OCCUPATION	Fringe Benefits Must Be Paid On <u>All</u> Hours Worked		
		HOURLY BASIC RATE OF PAY \$	HOURLY FRINGE BENEFITS \$	TOTAL \$
103	Bricklayer, Blocklayer or Stonemason	31.55	18.52	50.07
105	Carpenter Future Increase(s): Add \$1.42/hr on 6/1/2016. Premium Increase(s): DOT PREMIUM: Pay two times the hourly basic rate on Sunday, New Year's Day, Memorial Day, Independence Day, Labor Day, Thanksgiving Day & Christmas Day.	33.02	17.12	50.14
107	Cement Finisher Future Increase(s): Add \$1.75 on 6/1/16. Premium Increase(s): DOT PREMIUMS: 1) Pay two times the hourly basic rate on Sunday, New Year's Day, Memorial Day, Independence Day, Labor Day, Thanksgiving Day & Christmas Day. 2) Add \$1.40/hr when the Wisconsin Department of Transportation or responsible governing agency requires that work be performed at night under artificial illumination with traffic control and the work is completed after sunset and before sunrise.	35.97	17.85	53.82
109	Electrician Future Increase(s): Add \$1.25/hr on 6/1/16. Premium Increase(s): DOT PREMIUM: Pay two times the hourly basic rate on Sunday, New Year's Day, Memorial Day, Independence Day, Labor Day, Thanksgiving Day & Christmas Day.	35.75	19.97	55.72
111	Fence Erector	35.62	0.00	35.62
116	Ironworker	32.50	20.58	53.08
118	Line Constructor (Electrical)	40.81	18.06	58.87
124	Painter	29.87	18.79	48.66
125	Pavement Marking Operator	31.24	17.30	48.54
126	Piledriver	30.11	21.09	51.20
133	Roofer or Waterproofer	30.40	2.23	32.63
137	Teledata Technician or Installer	22.50	12.74	35.24
143	Tuckpointer, Caulker or Cleaner	32.82	18.67	51.49

Fringe Benefits Must Be Paid On <u>All</u> Hours Worked		HOURLY BASIC RATE OF PAY	HOURLY FRINGE BENEFITS	TOTAL
CODE	TRADE OR OCCUPATION	\$	\$	\$
144	Underwater Diver (Except on Great Lakes)	36.74	16.00	52.74
150	Heavy Equipment Operator - ELECTRICAL LINE CONSTRUCTION ONLY	36.73	15.92	52.65
151	Light Equipment Operator -ELECTRICAL LINE CONSTRUCTION ONLY	32.65	17.37	50.02
152	Heavy Truck Driver - ELECTRICAL LINE CONSTRUCTION ONLY	28.57	13.71	42.28
153	Light Truck Driver - ELECTRICAL LINE CONSTRUCTION ONLY	26.53	13.09	39.62
154	Groundman - ELECTRICAL LINE CONSTRUCTION ONLY	21.75	12.97	34.72
TRUCK DRIVERS				

Fringe Benefits Must Be Paid On <u>All</u> Hours Worked		HOURLY BASIC RATE OF PAY	HOURLY FRINGE BENEFITS	TOTAL
CODE	TRADE OR OCCUPATION	\$	\$	\$
201	Single Axle or Two Axle	36.72	21.15	57.87
203	Three or More Axle Premium Increase(s): DOT PREMIUM: Pay two times the hourly basic rate on Sunday, New Year's Day, Memorial Day, Independence Day, Labor Day, Thanksgiving Day & Christmas Day.	25.78	18.96	44.74
204	Articulated, Euclid, Dumptor, Off Road Material Hauler Future Increase(s): Add \$1.30/hr on 6/1/2016; Add \$1.25/hr on 6/1/2017. Premium Increase(s): DOT PREMIUMS: 1) Pay two times the hourly basic rate on Sunday, New Year's Day, Memorial Day, Independence Day, Labor Day, Thanksgiving Day & Christmas Day. 2) Add \$1.50/hr night work premium. See DOT'S website for details about the applicability of this night work premium at: http://wisconsindot.gov/Pages/doing-bus/civil-rights/labornwage/prevaling-wage-compliance.aspx .	30.82	21.85	52.67
205	Pavement Marking Vehicle	23.82	17.72	41.54
206	Shadow or Pilot Vehicle	25.28	18.31	43.59
207	Truck Mechanic	25.28	18.31	43.59

LABORERS

Fringe Benefits Must Be Paid On <u>All</u> Hours Worked		HOURLY BASIC RATE OF PAY	HOURLY FRINGE BENEFITS	TOTAL
CODE	TRADE OR OCCUPATION	\$	\$	\$
301	General Laborer Future Increase(s): Add \$1.00/hr eff. 06/01/2016; Add \$1.00/hr eff. 06/01/2017 Premium Increase(s): Add \$.10/hr for topman, air tool operator, vibrator or tamper operator (mechanical hand operated), chain saw operator and demolition burning torch laborer; Add \$.15/hr for bituminous worker (raker and luteman), formsetter (curb, sidewalk and pavement) and strike off man; Add \$.20/hr for blaster and powderman; Add \$.25/hr for bottomman; Add \$.35/hr for line and grade specialist; Add \$.45/hr for pipelayer. / DOT PREMIUMS: 1) Pay two times the hourly basic rate on Sunday, New Year's Day, Memorial Day, Independence Day, Labor Day, Thanksgiving Day & Christmas Day. 2) Add \$1.25/hr for work on projects involving temporary traffic control setup, for lane and shoulder closures, when work under artificial illumination conditions is necessary as required by the project provisions (including prep time prior to and/or cleanup after such time period).	30.95	15.65	46.60
302	Asbestos Abatement Worker	17.00	4.22	21.22
303	Landscaper Future Increase(s): Add \$1.00/hr eff. 06/01/2016; Add \$1.00/hr eff. 06/01/2017 Premium Increase(s): DOT PREMIUMS: 1) Pay two times the hourly basic rate on Sunday, New Year's Day, Memorial Day, Independence Day, Labor Day, Thanksgiving Day & Christmas Day. 2) Add \$1.25/hr for work on projects involving temporary traffic control setup, for lane and shoulder closures, when work under artificial illumination conditions is necessary as required by the project provisions (including prep time prior to and/or cleanup after such time period).	30.95	15.65	46.60
304	Flagperson or Traffic Control Person Future Increase(s): Add \$1.00/hr eff. 06/01/2016; Add \$1.00/hr eff. 06/01/2017 Premium Increase(s): DOT PREMIUMS: 1) Pay two times the hourly basic rate on Sunday, New Year's Day, Memorial Day, Independence Day, Labor Day, Thanksgiving Day & Christmas Day. 2) Add \$1.25/hr when the Wisconsin Department of Transportation or responsible governing agency requires that work be performed at night under artificial illumination with traffic control and the work is completed after sunset and before sunrise.	27.30	15.65	42.95

Fringe Benefits Must Be Paid On <u>All</u> Hours Worked		HOURLY BASIC RATE OF PAY	HOURLY FRINGE BENEFITS	TOTAL
CODE	TRADE OR OCCUPATION	\$	\$	\$
311	Fiber Optic Laborer (Outside, Other Than Concrete Encased)	19.35	0.00	19.35
314	Railroad Track Laborer	17.00	3.96	20.96

**HEAVY EQUIPMENT OPERATORS
AIRPORT PAVEMENT OR STATE HIGHWAY CONSTRUCTION**

Fringe Benefits Must Be Paid On <u>All</u> Hours Worked		HOURLY BASIC RATE OF PAY	HOURLY FRINGE BENEFITS	TOTAL
CODE	TRADE OR OCCUPATION	\$	\$	\$
531	Crane, Tower Crane, Pedestal Tower or Derrick, With Boom, Leads &/or Jib Lengths Measuring 176 Ft or Over; Crane, Tower Crane, Pedestal Tower or Derrick, With or Without Attachments, With a Lifting Capacity of Over 100 Tons, Self-Erecting Tower Crane With a Lifting Capacity Of Over 4,000 Lbs., Crane With Boom Dollies; Traveling Crane (Bridge Type). Future Increase(s): Add \$1.30/hr on 6/1/2016; Add \$1.25/hr on 6/1/2017. Premium Increase(s): DOT PREMIUMS: 1) Pay two times the hourly basic rate on Sunday, New Year's Day, Memorial Day, Independence Day, Labor Day, Thanksgiving Day & Christmas Day. 2) Add \$1.50/hr night work premium. See DOT'S website for details about the applicability of this night work premium at: http://wisconsindot.gov/Pages/doing-bus/civil-rights/labornwage/prevailing-wage-compliance.aspx .	38.27	21.85	60.12
532	Backhoe (Track Type) Having a Mfgr.'s Rated Capacity of 130,000 Lbs. or Over; Caisson Rig; Crane, Tower Crane, Portable Tower, Pedestal Tower or Derrick, With Boom, Leads &/or Jib Lengths Measuring 175 Ft or Under; Crane, Tower Crane, Portable Tower, Pedestal Tower or Derrick, With or Without Attachments, With a Lifting Capacity of 100 Tons or Under, Self-Erecting Tower Crane With A Lifting Capacity Of 4,000 Lbs., & Under; Dredge (NOT Performing Work on the Great Lakes); Licensed Boat Pilot (NOT Performing Work on the Great Lakes); Pile Driver. Future Increase(s): Add \$1.30/hr on 6/1/2016; Add \$1.25/hr on 6/1/2017. Premium Increase(s): DOT PREMIUMS: 1) Pay two times the hourly basic rate on Sunday, New Year's Day, Memorial Day, Independence Day, Labor Day, Thanksgiving Day & Christmas Day. 2) Add \$1.50/hr night work premium. See DOT'S website for details about the applicability of this night work premium at: http://wisconsindot.gov/Pages/doing-bus/civil-rights/labornwage/prevailing-wage-compliance.aspx .	37.77	21.85	59.62

Fringe Benefits Must Be Paid On <u>All</u> Hours Worked		HOURLY BASIC RATE OF PAY	HOURLY FRINGE BENEFITS	TOTAL
CODE	TRADE OR OCCUPATION	\$	\$	\$
533	<p>Air Track, Rotary or Percussion Drilling Machine &/or Hammers, Blaster; Asphalt Heater, Planer & Scarifier; Asphalt Milling Machine; Asphalt Screed; Automatic Subgrader (Concrete); Backhoe (Track Type) Having a Mfgr.'s Rated Capacity of Under 130,000 Lbs., Backhoe (Mini, 15,000 Lbs. & Under); Bituminous (Asphalt) Plant & Paver, Screed; Boatmen (NOT Performing Work on the Great Lakes); Boring Machine (Directional, Horizontal or Vertical); Bridge (Bidwell) Paver; Bulldozer or Endloader; Concrete Batch Plant, Batch Hopper; Concrete Breaker (Large, Auto, Vibratory/Sonic, Manual or Remote); Concrete Bump Cutter, Grinder, Planing or Grooving Machine; Concrete Conveyor System; Concrete Laser/Screed; Concrete Paver (Slipform); Concrete Pump, Concrete Conveyor (Rotec or Bidwell Type); Concrete Slipform Placer Curb & Gutter Machine; Concrete Spreader & Distributor; Crane (Carry Deck, Mini) or Truck Mounted Hydraulic Crane (10 Tons or Under); Crane Wlth a Lifting Capacity of 25 Tons or Under; Forestry Equipment, Timbco, Tree Shear, Tub Grinder, Processor; Gradall (Cruz-Aire Type); Grader or Motor Patrol; Grout Pump; Hydro-Blaster (10,000 PSI or Over); Loading Machine (Conveyor); Material or Stack Hoist; Mechanic or Welder; Milling Machine; Post Hole Digger or Driver; Roller (Over 5 Ton); Scraper (Self Propelled or Tractor Drawn) 5 cu yds or More Capacity; Shoulder Widener; Sideboom; Skid Rig; Stabilizing or Concrete Mixer (Self-Propelled or 14S or Over); Straddle Carrier or Travel Lift; Tractor (Scraper, Dozer, Pusher, Loader); Tractor or Truck Mounted Hydraulic Backhoe; Trencher (Wheel Type or Chain Type); Tube Finisher; Tugger (NOT Performing Work on the Great Lakes); Winches & A-Frames.</p> <p>Future Increase(s): Add \$1.30/hr on 6/1/2016; Add \$1.25/hr on 6/1/2017.</p> <p>Premium Increase(s): DOT PREMIUMS: 1) Pay two times the hourly basic rate on Sunday, New Year's Day, Memorial Day, Independence Day, Labor Day, Thanksgiving Day & Christmas Day. 2) Add \$1.50/hr night work premium. See DOT'S website for details about the applicability of this night work premium at: http://wisconsin.gov/Pages/doing-bus/civil-rights/labornwage/prevailing-wage-compliance.aspx.</p>	37.27	21.85	59.12

Fringe Benefits Must Be Paid On <u>All</u> Hours Worked		HOURLY BASIC RATE OF PAY	HOURLY FRINGE BENEFITS	TOTAL
CODE	TRADE OR OCCUPATION	\$	\$	\$
534	<p>Belting, Burlap, Texturing Machine; Broom or Sweeper; Compactor (Self-Propelled or Tractor Mounted, Towed & Light Equipment); Concrete Finishing Machine (Road Type); Environmental Burner; Farm or Industrial Type Tractor; Fireman (Asphalt Plant, Pile Driver & Derrick NOT Performing Work on the Great Lakes); Forklift; Greaser; Hoist (Tugger, Automatic); Jeep Digger; Joint Sawyer (Multiple Blade); Launch (NOT Performing Work on the Great Lakes); Lift Slab Machine; Mechanical Float; Mulcher; Power Subgrader; Robotic Tool Carrier (With or Without Attachments); Roller (Rubber Tire, 5 Ton or Under); Self Propelled Chip Spreader; Shouldering Machine; Skid Steer Loader (With or Without Attachments); Telehandler; Tining or Curing Machine.</p> <p>Future Increase(s): Add \$1.30/hr on 6/1/2016; Add \$1.25/hr on 6/1/2017.</p> <p>Premium Increase(s): DOT PREMIUMS: 1) Pay two times the hourly basic rate on Sunday, New Year's Day, Memorial Day, Independence Day, Labor Day, Thanksgiving Day & Christmas Day. 2) Add \$1.50/hr night work premium. See DOT'S website for details about the applicability of this night work premium at: http://wisconsin.gov/Pages/doing-bus/civil-rights/labornwage/prevaling-wage-compliance.aspx.</p>	37.01	21.85	58.86
535	<p>Air Compressor (&/or 400 CFM or Over); Air, Electric or Hydraulic Jacking System; Augers (Vertical & Horizontal); Automatic Belt Conveyor & Surge Bin; Boiler (Temporary Heat); Concrete Proportioning Plant; Crusher, Screening or Wash Plant; Generator (&/or 150 KW or Over); Heaters (Mechanical); High Pressure Utility Locating Machine (Daylighting Machine); Mudjack; Oiler; Prestress Machine; Pug Mill; Pump (3 Inch or Over) or Well Points; Rock, Stone Breaker; Screed (Milling Machine); Stump Chipper; Tank Car Heaters; Vibratory Hammer or Extractor, Power Pack.</p> <p>Future Increase(s): Add \$1.30/hr on 6/1/2016; Add \$1.25/hr on 6/1/2017.</p> <p>Premium Increase(s): DOT PREMIUMS: 1) Pay two times the hourly basic rate on Sunday, New Year's Day, Memorial Day, Independence Day, Labor Day, Thanksgiving Day & Christmas Day. 2) Add \$1.50/hr night work premium. See DOT'S website for details about the applicability of this night work premium at: http://wisconsin.gov/Pages/doing-bus/civil-rights/labornwage/prevaling-wage-compliance.aspx.</p>	36.72	21.85	58.57
536	Fiber Optic Cable Equipment.	29.50	0.68	30.18
537	Work Performed on the Great Lakes Including Diver; Wet Tender or Hydraulic Dredge Engineer.	41.65	21.71	63.36
538	Work Performed on the Great Lakes Including 70 Ton & Over Tug Operator; Assistant Hydraulic Dredge Engineer; Crane or Backhoe Operator; Hydraulic Dredge Leverman or Diver's Tender; Mechanic or Welder.	41.65	21.71	63.36

Fringe Benefits Must Be Paid On <u>All</u> Hours Worked		HOURLY BASIC RATE OF PAY	HOURLY FRINGE BENEFITS	TOTAL
CODE	TRADE OR OCCUPATION	\$	\$	\$
539	Work Performed on the Great Lakes Including Deck Equipment Operator or Machineryman (Maintains Cranes Over 50 Tons or Backhoes 115,000 Lbs. or More); Tug, Launch or Loader, Dozer or Like Equipment When Operated on a Barge, Breakwater Wall, Slip, Dock or Scow, Deck Machinery.	36.72	21.15	57.87
540	Work Performed on the Great Lakes Including Deck Equipment Operator, Machineryman or Fireman (Operates 4 Units or More or Maintains Cranes 50 Tons or Under or Backhoes 115,000 Lbs. or Under); Deck Hand, Deck Engineer or Assistant Tug Operator; Off Road Trucks-Great Lakes ONLY.	36.72	21.15	57.87

LOCAL STREET OR MISCELLANEOUS PAVING CONSTRUCTION
--

Includes roads, streets, alleys, trails, bridges, paths, racetracks, parking lots and driveways (except residential or agricultural), public sidewalks or other similar projects (excluding projects awarded by the Wisconsin Department of Transportation).

SKILLED TRADES

CODE	TRADE OR OCCUPATION	HOURLY BASIC RATE OF PAY	HOURLY FRINGE BENEFITS	TOTAL
		\$	\$	\$
103	Bricklayer, Blocklayer or Stonemason	32.82	18.67	51.49
105	Carpenter Future Increase(s): Add \$1.42/hr on 6/1/2016. Premium Increase(s): DOT PREMIUM: Pay two times the hourly basic rate on Sunday, New Year's Day, Memorial Day, Independence Day, Labor Day, Thanksgiving Day & Christmas Day.	33.02	17.12	50.14
107	Cement Finisher Future Increase(s): Add \$1.75 on 6/1/16. Premium Increase(s): DOT PREMIUMS: 1) Pay two times the hourly basic rate on Sunday, New Year's Day, Memorial Day, Independence Day, Labor Day, Thanksgiving Day & Christmas Day. 2) Add \$1.40/hr when the Wisconsin Department of Transportation or responsible governing agency requires that work be performed at night under artificial illumination with traffic control and the work is completed after sunset and before sunrise.	35.97	17.85	53.82
109	Electrician Future Increase(s): Add \$1.25/hr on 6/1/16. Premium Increase(s): DOT PREMIUM: Pay two times the hourly basic rate on Sunday, New Year's Day, Memorial Day, Independence Day, Labor Day, Thanksgiving Day & Christmas Day.	35.75	19.97	55.72
111	Fence Erector	18.72	5.78	24.50
116	Ironworker	32.50	20.58	53.08
118	Line Constructor (Electrical)	40.81	18.06	58.87
124	Painter	26.70	16.65	43.35
125	Pavement Marking Operator	30.00	18.81	48.81
126	Piledriver Future Increase(s): Add \$1.44/hr on 6/1/2016. Premium Increase(s): DOT PREMIUM: Pay two times the hourly basic rate on Sunday, New Year's Day, Memorial Day, Independence Day, Labor Day, Thanksgiving Day & Christmas Day.	33.56	17.12	50.68

Fringe Benefits Must Be Paid On <u>All</u> Hours Worked		HOURLY BASIC RATE OF PAY	HOURLY FRINGE BENEFITS	TOTAL
CODE	TRADE OR OCCUPATION	\$	\$	\$
133	Roofer or Waterproofer	29.65	1.71	31.36
137	Teledata Technician or Installer	22.50	12.74	35.24
143	Tuckpointer, Caulker or Cleaner	32.82	18.67	51.49
144	Underwater Diver (Except on Great Lakes)	36.74	16.00	52.74
150	Heavy Equipment Operator - ELECTRICAL LINE CONSTRUCTION ONLY	36.73	15.92	52.65
151	Light Equipment Operator -ELECTRICAL LINE CONSTRUCTION ONLY	32.65	15.52	48.17
152	Heavy Truck Driver - ELECTRICAL LINE CONSTRUCTION ONLY	28.57	13.71	42.28
153	Light Truck Driver - ELECTRICAL LINE CONSTRUCTION ONLY	26.53	13.55	40.08
154	Groundman - ELECTRICAL LINE CONSTRUCTION ONLY	21.75	12.97	34.72

TRUCK DRIVERS

Fringe Benefits Must Be Paid On <u>All</u> Hours Worked		HOURLY BASIC RATE OF PAY	HOURLY FRINGE BENEFITS	TOTAL
CODE	TRADE OR OCCUPATION	\$	\$	\$
201	Single Axle or Two Axle	18.00	0.00	18.00
203	Three or More Axle	18.00	0.00	18.00
204	Articulated, Euclid, Dumptor, Off Road Material Hauler Future Increase(s): Add \$1.60/hr on 6/3/2016.	34.69	20.38	55.07
205	Pavement Marking Vehicle	18.00	0.00	18.00
206	Shadow or Pilot Vehicle	18.00	0.00	18.00
207	Truck Mechanic	18.00	0.00	18.00

LABORERS

Fringe Benefits Must Be Paid On <u>All</u> Hours Worked		HOURLY BASIC RATE OF PAY	HOURLY FRINGE BENEFITS	TOTAL
CODE	TRADE OR OCCUPATION	\$	\$	\$
301	General Laborer	26.34	15.17	41.51

Fringe Benefits Must Be Paid On <u>All</u> Hours Worked		HOURLY BASIC RATE OF PAY	HOURLY FRINGE BENEFITS	TOTAL
CODE	TRADE OR OCCUPATION	\$	\$	\$
303	Landscaper Future Increase(s): Add \$1.00/hr eff. 06/01/2016; Add \$1.00/hr eff. 06/01/2017 Premium Increase(s): DOT PREMIUMS: 1) Pay two times the hourly basic rate on Sunday, New Year's Day, Memorial Day, Independence Day, Labor Day, Thanksgiving Day & Christmas Day. 2) Add \$1.25/hr for work on projects involving temporary traffic control setup, for lane and shoulder closures, when work under artificial illumination conditions is necessary as required by the project provisions (including prep time prior to and/or cleanup after such time period).	30.67	15.65	46.32
304	Flagperson or Traffic Control Person	20.92	14.80	35.72
311	Fiber Optic Laborer (Outside, Other Than Concrete Encased)	19.35	0.00	19.35
314	Railroad Track Laborer	17.00	3.96	20.96

**HEAVY EQUIPMENT OPERATORS
CONCRETE PAVEMENT OR BRIDGE WORK**

Fringe Benefits Must Be Paid On <u>All</u> Hours Worked		HOURLY BASIC RATE OF PAY	HOURLY FRINGE BENEFITS	TOTAL
CODE	TRADE OR OCCUPATION	\$	\$	\$
541	Crane, Tower Crane, Pedestal Tower or Derrick, With or Without Attachments, With a Lifting Capacity of Over 100 Tons, Self-Erecting Tower Crane With a Lifting Capacity Of Over 4,000 Lbs., Crane With Boom Dollies; Crane, Tower Crane, Pedestal Tower or Derrick, With Boom, Leads &/or Jib Lengths Measuring 176 Ft or Over; Master Mechanic. Future Increase(s): Add \$1.60/hr on 6/3/2016. Premium Increase(s): Add \$.50/hr for >200 Ton; Add \$1/hr at 300 Ton; Add \$1.50/hr at 400 Ton; Add \$2/hr at 500 Ton & Over.	37.67	20.38	58.05

Fringe Benefits Must Be Paid On <u>All</u> Hours Worked		HOURLY BASIC RATE OF PAY	HOURLY FRINGE BENEFITS	TOTAL
CODE	TRADE OR OCCUPATION	\$	\$	\$
542	<p>Backhoe (Track Type) Having a Mfgr.'s Rated Capacity of 130,000 Lbs. or Over; Caisson Rig; Crane, Tower Crane, Portable Tower, Pedestal Tower or Derrick, With or Without Attachments, With a Lifting Capacity of 100 Tons or Under, Self-Erecting Tower Crane With a Lifting Capacity of 4,000 Lbs. & Under; Crane, Tower Crane Portable Tower, Pedestal Tower or Derrick, With Boom, Leads &/or Jib Lengths Measuring 175 Ft or Under; Dredge (NOT Performing Work on the Great Lakes); Licensed Boat Pilot (NOT Performing Work on the Great Lakes); Pile Driver.</p> <p>Future Increase(s): Add \$1.30/hr on 6/1/2016; Add \$1.25/hr on 6/1/2017.</p> <p>Premium Increase(s): DOT PREMIUMS: 1) Pay two times the hourly basic rate on Sunday, New Year's Day, Memorial Day, Independence Day, Labor Day, Thanksgiving Day & Christmas Day. 2) Add \$1.50/hr night work premium. See DOT'S website for details about the applicability of this night work premium at: http://wisconsin.gov/Pages/doing-bus/civil-rights/labornwage/prevaling-wage-compliance.aspx.</p>	37.77	21.85	59.62
543	<p>Air Track, Rotary or Percussion Drilling Machine &/or Hammers, Blaster; Automatic Subgrader (Concrete); Backhoe (Track Type) Having a Mfgr.'s Rated Capacity of Under 130,000 Lbs., Backhoe (Mini, 15,000 Lbs. & Under); Boring Machine (Directional, Horizontal or Vertical); Bridge (Bidwell) Paver; Bulldozer or Endloader; Concrete Batch Plant, Batch Hopper; Concrete Breaker (Large, Auto, Vibratory/Sonic, Manual or Remote); Concrete Bump Cutter, Grinder, Planing or Grooving Machine; Concrete Conveyor System; Concrete Laser/Screed; Concrete Paver (Slipform); Concrete Pump, Concrete Conveyor (Rotec or Bidwell Type); Concrete Slipform Placer Curb & Gutter Machine; Concrete Spreader & Distributor; Crane (Carry Deck, Mini) or Truck Mounted Hydraulic Crane (10 Tons or Under); Crane With a Lifting Capacity of 25 Tons or Under; Forestry Equipment, Timbco, Tree Shear, Tub Grinder, Processor; Gradall (Cruz-Aire Type); Grader or Motor Patrol; Grout Pump; Hydro-Blaster (10,000 PSI or Over); Loading Machine (Conveyor); Manhoist; Material or Stack Hoist; Mechanic or Welder; Milling Machine; Post Hole Digger or Driver; Scraper (Self Propelled or Tractor Drawn) 5 cu yds or More Capacity; Shoulder Widener; Sideboom; Skid Rig; Stabilizing or Concrete Mixer (Self-Propelled or 14S or Over); Straddle Carrier or Travel Lift; Tractor (Scraper, Dozer, Pusher, Loader); Tractor or Truck Mounted Hydraulic Backhoe; Trencher (Wheel Type or Chain Type); Tube Finisher; Tugger (NOT Performing Work on the Great Lakes); Winches & A-Frames.</p> <p>Future Increase(s): Add \$1.30/hr on 6/1/2016; Add \$1.25/hr on 6/1/2017.</p> <p>Premium Increase(s): DOT PREMIUMS: 1) Pay two times the hourly basic rate on Sunday, New Year's Day, Memorial Day, Independence Day, Labor Day, Thanksgiving Day & Christmas Day. 2) Add \$1.50/hr night work premium. See DOT'S website for details about the applicability of this night work premium at: http://wisconsin.gov/Pages/doing-bus/civil-rights/labornwage/prevaling-wage-compliance.aspx.</p>	37.27	21.85	59.12

Fringe Benefits Must Be Paid On <u>All</u> Hours Worked		HOURLY BASIC RATE OF PAY	HOURLY FRINGE BENEFITS	TOTAL
CODE	TRADE OR OCCUPATION	\$	\$	\$
544	Backfiller; Belting, Burlap, Texturing Machine; Broom or Sweeper; Compactor (Self-Propelled or Tractor Mounted, Towed & Light Equipment); Concrete Finishing Machine (Road Type); Environmental Burner; Farm or Industrial Type Tractor; Fireman (Pile Driver & Derrick NOT Performing Work on the Great Lakes); Forklift; Greaser; Jeep Digger; Joint Sawyer (Multiple Blade); Launch (NOT Performing Work on the Great Lakes); Lift Slab Machine; Mechanical Float; Mulcher; Power Subgrader; Robotic Tool Carrier (With or Without Attachments); Self Propelled Chip Spreader; Shouldering Machine; Skid Steer Loader (With or Without Attachments); Telehandler; Tining or Curing Machine. Future Increase(s): Add \$1.30/hr on 6/1/2016; Add \$1.25/hr on 6/1/2017. Premium Increase(s): DOT PREMIUMS: 1) Pay two times the hourly basic rate on Sunday, New Year's Day, Memorial Day, Independence Day, Labor Day, Thanksgiving Day & Christmas Day. 2) Add \$1.50/hr night work premium. See DOT'S website for details about the applicability of this night work premium at: http://wisconsindot.gov/Pages/doing-bus/civil-rights/labornwage/prevailing-wage-compliance.aspx .	37.27	21.85	59.12
545	Air Compressor (&/or 400 CFM or Over); Air, Electric or Hydraulic Jacking System; Automatic Belt Conveyor & Surge Bin; Boiler (Temporary Heat); Concrete Proportioning Plant; Crusher, Screening or Wash Plant; Generator (&/or 150 KW or Over); Heaters (Mechanical); High Pressure Utility Locating Machine (Daylighting Machine); Mudjack; Oiler; Prestress Machine; Pug Mill; Pump (3 Inch or Over) or Well Points; Rock, Stone Breaker; Screed (Milling Machine); Stump Chipper; Tank Car Heaters; Vibratory Hammer or Extractor, Power Pack.	31.62	19.78	51.40
546	Fiber Optic Cable Equipment.	29.50	0.68	30.18
547	Work Performed on the Great Lakes Including Diver; Wet Tender or Hydraulic Dredge Engineer.	41.65	21.71	63.36
548	Work Performed on the Great Lakes Including 70 Ton & Over Tug Operator; Assistant Hydraulic Dredge Engineer; Crane or Backhoe Operator; Hydraulic Dredge Leverman or Diver's Tender; Mechanic or Welder. Future Increase(s): Add \$1.25/hr on 1/1/2017. Premium Increase(s): Add \$.50/hr for Friction Crane, Lattice Boom or Crane Certification (CCO).	44.05	23.24	67.29
549	Work Performed on the Great Lakes Including Deck Equipment Operator or Machineryman (Maintains Cranes Over 50 Tons or Backhoes 115,000 Lbs. or more); Tug, Launch or Loader, Dozer or Like Equipment When Operated on a Barge, Breakwater Wall, Slip, Dock or Scow, Deck Machinery.	36.72	21.15	57.87

550	Work Performed on the Great Lakes Including Deck Equipment Operator; Machineryman or Fireman (Operates 4 Units or More or Maintains Cranes 50 Tons or Under or Backhoes 115,000 Lbs. or Under); Deck Hand, Deck Engineer or Assistant Tug Operator; Off Road Trucks - Great Lakes ONLY.	36.72	21.15	57.87
-----	---	-------	-------	-------

**HEAVY EQUIPMENT OPERATORS
ASPHALT PAVEMENT OR OTHER WORK**

Fringe Benefits Must Be Paid On <u>All</u> Hours Worked		HOURLY BASIC RATE OF PAY	HOURLY FRINGE BENEFITS	TOTAL
CODE	TRADE OR OCCUPATION	\$	\$	\$
551	Crane, Tower Crane, Pedestal Tower or Derrick, With or Without Attachments, With a Lifting Capacity of Over 100 Tons, Self Erecting Tower Crane With a Lifting Capacity of Over 4,000 Lbs., Crane With Boom Dollies; Crane, Tower Crane, Pedestal Tower or Derrick, With Boom, Leads and/or Jib Lengths Measuring 176 Ft or Over; Master Mechanic.	36.67	19.78	56.45
552	Backhoe (Track Type) Having a Mfgr.'s Rated Capacity of 130,000 Lbs. or Over; Caisson Rig; Crane, Tower Crane, Portable Tower, Pedestal Tower or Derrick, With or Without Attachments, With a Lifting Capacity of 100 Tons or Under, Self-Erecting Tower Crane With a Lifting Capacity Of 4,000 Lbs. & Under; Crane, Tower Crane, Portable Tower, Pedestal Tower or Derrick, With Boom, Leads &/or Jib Lengths Measuring 175 Ft or Under; Dredge (NOT Performing Work on the Great Lakes); Licensed Boat Pilot (NOT Performing Work on the Great Lakes); Pile Driver. Future Increase(s): Add \$1.30/hr on 6/1/2016; Add \$1.25/hr on 6/1/2017. Premium Increase(s): DOT PREMIUMS: 1) Pay two times the hourly basic rate on Sunday, New Year's Day, Memorial Day, Independence Day, Labor Day, Thanksgiving Day & Christmas Day. 2) Add \$1.50/hr night work premium. See DOT'S website for details about the applicability of this night work premium at: http://wisconsindot.gov/Pages/doing-bus/civil-rights/labornwage/prevaling-wage-compliance.aspx .	37.77	21.85	59.62

Fringe Benefits Must Be Paid On <u>All</u> Hours Worked		HOURLY BASIC RATE OF PAY	HOURLY FRINGE BENEFITS	TOTAL
CODE	TRADE OR OCCUPATION	\$	\$	\$
553	Air, Track, Rotary or Percussion Drilling Machine &/or Hammers, Blaster; Asphalt Heater, Planer & Scarifier; Asphalt Milling Machine; Asphalt Screed; Backhoe (Track Type) Having a Mfgr.'s Rated Capacity of Under 130,000 Lbs., Backhoe (Mini, 15,000 Lbs. & Under); Bituminous (Asphalt) Plant & Paver, Screed; Boring Machine (Directional, Horizontal or Vertical); Bulldozer or Endloader; Concrete Breaker (Large, Auto, Vibratory/Sonic, Manual or Remote); Concrete Conveyor System; Concrete Laser/Screed; Concrete Slipform Placer Curb & Gutter Machine; Crane (Carry Deck, Mini) or Truck Mounted Hydraulic Crane (10 Tons or Under); Crane With a Lifting Capacity of 25 Tons or Under; Forestry Equipment, Timbco, Tree Shear, Tub Grinder, Processor; Gradall (Cruz-Aire Type); Grader or Motor Patrol; Hydro-Blaster (10,000 PSI or Over); Loading Machine (Conveyor); Manhoist; Material or Stack Hoist; Mechanic or Welder; Milling Machine; Post Hole Digger or Driver; Railroad Track Rail Leveling Machine, Tie Placer, Extractor, Tamper, Stone Leveler or Rehabilitation Equipment; Roller (Over 5 Ton); Scraper (Self Propelled or Tractor Drawn) 5 cu yds or More Capacity; Shoulder Widener; Sideboom; Skid Rig; Stabilizing or Concrete Mixer (Self-Propelled or 14S or Over); Tractor (Scraper, Dozer, Pusher, Loader); Tractor or Truck Mounted Hydraulic Backhoe; Trencher (Wheel Type or Chain Type); Tube Finisher; Tugger (NOT Performing Work on the Great Lakes); Winches & A-Frames. Future Increase(s): Add \$1.60/hr on 6/3/2016.	34.69	20.38	55.07
554	Backfiller; Broom or Sweeper; Compactor (Self-Propelled or Tractor Mounted, Towed & Light Equipment); Concrete Finishing Machine (Road Type); Environmental Burner; Farm or Industrial Type Tractor; Fireman (Asphalt Plant, Pile Driver & Derrick NOT Performing Work on the Great Lakes); Forklift; Greaser; Hoist (Tugger, Automatic); Jeep Digger; Joint Sawyer (Multiple Blade); Launch (NOT Performing Work on the Great Lakes); Lift Slab Machine; Mechanical Float; Mulcher; Power Subgrader; Robotic Tool Carrier (With or Without Attachments); Roller (Rubber Tire, 5 Ton or Under); Self-Propelled Chip Spreader; Shouldering Machine; Skid Steer Loader (With or Without Attachments); Telehandler.	36.17	19.19	55.36
555	Air Compressor (&/or 400 CFM or Over); Air, Electric or Hydraulic Jacking System; Augers (Vertical & Horizontal); Automatic Belt Conveyor & Surge Bin; Boiler (Temporary Heat); Crusher, Screening or Wash Plant; Generator (&/or 150 KW or Over); Heaters (Mechanical); High Pressure Utility Locating Machine (Daylighting Machine); Mudjack; Oiler; Prestress Machine; Pug Mill; Pump (3 Inch or Over) or Well Points; Rock, Stone Breaker; Screed (Milling Machine); Stump Chipper; Tank Car Heaters; Vibratory Hammer or Extractor, Power Pack. Future Increase(s): Add \$1.60/hr on 6/3/2016.	32.62	20.38	53.00
556	Fiber Optic Cable Equipment.	29.50	0.68	30.18

RESIDENTIAL OR AGRICULTURAL CONSTRUCTION

Includes single family houses or apartment buildings of no more than four (4) stories in height and all buildings, structures or facilities that are primarily used for agricultural or farming purposes, excluding commercial buildings. For classification purposes, the exterior height of a residential building, in terms of stories, is the primary consideration. All incidental items such as site work, driveways, parking lots, private sidewalks, private septic systems or sewer and water laterals connected to a public system and swimming pools are included within this definition. Residential buildings of five (5) stories and above are NOT included within this definition.

SKILLED TRADES

<u>CODE</u>	<u>TRADE OR OCCUPATION</u>	<u>HOURLY BASIC RATE OF PAY</u>	<u>HOURLY FRINGE BENEFITS</u>	<u>TOTAL</u>
		\$	\$	\$
101	Acoustic Ceiling Tile Installer	37.41	0.00	37.41
102	Boilermaker	33.35	28.29	61.64
103	Bricklayer, Blocklayer or Stonemason	32.82	9.93	42.75
104	Cabinet Installer	20.00	0.46	20.46
105	Carpenter	25.39	5.03	30.42
106	Carpet Layer or Soft Floor Coverer	24.04	4.89	28.93
107	Cement Finisher	23.86	3.43	27.29
108	Drywall Taper or Finisher	27.00	0.00	27.00
109	Electrician	20.00	12.47	32.47
110	Elevator Constructor	46.05	27.09	73.14
111	Fence Erector	19.45	4.70	24.15
112	Fire Sprinkler Fitter	33.00	18.96	51.96
113	Glazier	38.27	14.42	52.69
114	Heat or Frost Insulator	17.00	0.00	17.00
115	Insulator (Batt or Blown)	20.00	12.35	32.35
116	Ironworker	24.30	14.25	38.55
117	Lather	25.39	5.03	30.42
119	Marble Finisher	25.72	18.54	44.26
120	Marble Mason	32.82	9.93	42.75
121	Metal Building Erector	13.60	6.57	20.17
123	Overhead Door Installer	18.00	0.00	18.00
124	Painter	26.24	0.00	26.24
125	Pavement Marking Operator	30.00	18.81	48.81

Fringe Benefits Must Be Paid On <u>All</u> Hours Worked		HOURLY BASIC RATE OF PAY	HOURLY FRINGE BENEFITS	TOTAL
CODE	TRADE OR OCCUPATION	\$	\$	\$
129	Plasterer	30.00	9.21	39.21
130	Plumber	30.00	11.56	41.56
132	Refrigeration Mechanic	22.50	9.03	31.53
133	Roofer or Waterproofer	21.00	4.10	25.10
134	Sheet Metal Worker	23.22	5.45	28.67
135	Steamfitter	17.05	0.94	17.99
137	Teledata Technician or Installer	22.50	12.74	35.24
138	Temperature Control Installer	22.50	2.36	24.86
139	Terrazzo Finisher	25.72	18.54	44.26
140	Terrazzo Mechanic	33.67	17.82	51.49
141	Tile Finisher	30.00	0.00	30.00
142	Tile Setter Future Increase(s): Add \$1.45/hr on 6/06/2016.	31.59	19.61	51.20
143	Tuckpointer, Caulker or Cleaner	25.00	2.99	27.99
146	Well Driller or Pump Installer	29.00	0.64	29.64
147	Siding Installer	14.00	0.00	14.00

TRUCK DRIVERS

Fringe Benefits Must Be Paid On <u>All</u> Hours Worked		HOURLY BASIC RATE OF PAY	HOURLY FRINGE BENEFITS	TOTAL
CODE	TRADE OR OCCUPATION	\$	\$	\$
201	Single Axle or Two Axle	16.50	0.50	17.00
203	Three or More Axle	21.53	3.34	24.87
205	Pavement Marking Vehicle	21.53	3.34	24.87
207	Truck Mechanic	21.53	3.34	24.87

LABORERS

Fringe Benefits Must Be Paid On <u>All</u> Hours Worked		HOURLY BASIC RATE OF PAY	HOURLY FRINGE BENEFITS	TOTAL
CODE	TRADE OR OCCUPATION	\$	\$	\$
301	General Laborer	17.20	9.26	26.46
302	Asbestos Abatement Worker	18.00	3.22	21.22

Fringe Benefits Must Be Paid On <u>All</u> Hours Worked		HOURLY BASIC RATE OF PAY	HOURLY FRINGE BENEFITS	TOTAL
CODE	TRADE OR OCCUPATION	\$	\$	\$
303	Landscaper	15.00	4.03	19.03
311	Fiber Optic Laborer (Outside, Other Than Concrete Encased)	19.35	0.00	19.35
315	Final Construction Clean-Up Worker	15.00	0.00	15.00

**HEAVY EQUIPMENT OPERATORS
RESIDENTIAL OR AGRICULTURAL CONSTRUCTION**

Fringe Benefits Must Be Paid On <u>All</u> Hours Worked		HOURLY BASIC RATE OF PAY	HOURLY FRINGE BENEFITS	TOTAL
CODE	TRADE OR OCCUPATION	\$	\$	\$
557	Asphalt Heater, Planer & Scarifier; Asphalt Milling Machine; Asphalt Screed; Backhoe (Track Type); Backhoe (Mini, 15,000 Lbs. & Under); Bituminous (Asphalt) Plant & Paver, Screed; Boring Machine (Directional, Horizontal or Vertical); Bulldozer or Endloader; Concrete Breaker (Large, Auto, Vibratory/Sonic, Manual or Remote); Concrete Bump Cutter, Grinder, Planing or Grooving Machine; Concrete Conveyor System; Concrete Laser/Screed; Concrete Paver (Slipform); Concrete Pump, Concrete Conveyor (Rotec or Bidwell Type); Concrete Slipform Placer Curb & Gutter Machine; Concrete Spreader & Distributor; Crane (Carry Deck, Mini) or Truck Mounted Hydraulic Crane (10 Tons or Under); Crane With a Lifting Capacity of 25 Tons or Under; Crane, Shovel, Dragline, Clamshells; Forestry Equipment, TImbco, Tree Shear, Tub Grinder, Processor; Grader or Motor Patrol; Grout Pump; Hydro-Blaster (10,000 PSI or Over); Loading Machine (Conveyor); Manhoist; Material or Stack Hoist; Mechanic or Welder; Milling Machine; Roller (Over 5 Ton); Scraper (Self Propelled or Tractor Drawn) 5 cu yds or More Capacity; Shoulder Widener; Skid Rig; Stabilizing or Concrete Mixer (Self-Propelled or 14S or Over); Tractor (Scraper, Dozer, Pusher, Loader); Tractor or Truck Mounted Hydraulic Backhoe; Tractor or Truck Mounted Hydraulic Crane (10 Tons or Under); Trencher (Wheel Type or Chain Type); Winches & A-Frames.	34.22	19.55	53.77
558	Air Compressor (&/or 400 CFM or Over); Air, Electric or Hydraulic Jacking System; Backfiller; Belting, Burlap, Texturing Machine; Boiler (Temporary Heat); Broom or Sweeper; Compactor (Self-Propelled or Tractor Mounted, Towed & Light Equipment); Concrete Finishing Machine (Road Type); Farm or Industrial Type Tractor; Forklift; Generator (&/or 150 KW or Over); Heaters (Mechanical); High Pressure Utility Locating Machine (Daylighting Machine); Jeep Digger; Lift Slab Machine; Mulcher; Oiler; Post Hole Digger or Driver; Power Subgrader; Pump (3 Inch or Over) or Well Points; Robotic Tool Carrier (With or Without Attachments); Rock, Stone Breaker; Roller (Rubber Tire, 5 Tons or Under); Screed (Milling Machine); Self Propelled Chip Spreader; Shouldering Machine; Skid Steer Loader (With or Without Attachments); Stump Chipper; Telehandler; Vibratory Hammer or Extractor, Power Pack. Future Increase(s): Add \$1.60/hr on 6/3/2016.	31.99	20.38	52.37

***** END OF RATES *****

THE 2015-17 BUDGET BILL MADE SIGNIFICANT CHANGES TO WISCONSIN'S PREVAILING WAGE LAWS. HOWEVER, THOSE CHANGES DO NOT GO INTO EFFECT UNTIL JANUARY 1, 2017.

During calendar year 2016, DWD will continue to enforce prevailing wage laws for local governmental unit and state agency public works projects under current prevailing wage laws.

2015 Wisconsin Act 55 (the budget bill) repealed the state prevailing wage law for **local governmental units** such as villages, towns, cities, school districts, or sewerage districts effective January 1, 2017. However, if a local governmental unit:

- issues a Request for Bids before January 1, 2017, for a project of public works that is subject to bidding or,
- enters into a contract before January 1, 2017, for a project of public works that is not subject to bidding,

then those public works projects are subject to the current prevailing wage law (§66.0903, Wis. Stats.) through the life of the project. Projects of public works with prevailing wage project determinations issued prior to 2017 continue to be subject to the current prevailing wage law through the life of the project even though the project may have work going on in 2017 or subsequent years.

Contractors working on local governmental unit projects with prevailing wage rate determinations must continue to pay employees the appropriate prevailing wage and maintain required prevailing wage payroll records. For instance, if a contractor is working in 2018 on a public works project with a project determination issued prior to 2017, then the contractor is required to comply with the "old" prevailing wage rate law (§66.0903, Wis. Stats.). After January 1, 2017, DWD will continue to enforce prevailing wage requirements for projects with DWD prevailing wage determinations issued under the "old" prevailing wage laws (§§ 66.0903 & 103.49, Wis. Stats.).

For new public works projects starting on January 1, 2017, state prevailing wage law will only apply to **state agency** and **state highway** projects. Prevailing wage rates applicable to state agencies will be those issued by the U.S. Department of Labor under the Davis-Bacon Act, 40 U.S.C. 3142. The Wisconsin Department of Administration will enforce the new state agency prevailing wage law (§16.856, Wis. Stats.) and the Wisconsin Department of Transportation will continue to enforce prevailing wage on state highway projects (under a law renumbered as §84.062, Wis. Stats.).

POST THE WHITE SHEET

As the public entity receiving this prevailing wage rate determination, **YOU ARE REQUIRED** by law to post the prevailing wage rate determination (i.e., white sheet) in at least one conspicuous and easily accessible place on the project site that is available to all construction workers. The white sheet must remain posted from the onset of the project until all construction labor on the project has been completed.

[See, Wis. Admin. Code §DWD 290.12(1)]

Posting the white sheet inside the general contractor's trailer does not meet this requirement. That placement is not available/accessible to all workers and is not a location over which you have control.

If you have questions about posting, please call (608)266-6861 and ask for prevailing wage intake.

PREVAILING WAGE – Contractors

Any public works project that has a total estimated project cost that equals or exceeds prevailing wage project thresholds requires a prevailing wage rate determination issued by the Department of Workforce Development (DWD). Public works include erecting, constructing, remodeling, repairing, demolishing, alterations, painting and decorating projects for a local governmental unit or state agency. State law excludes minor service or maintenance work, warranty work, or work under a supply-and-installation contract. There is a statutory definition for most of these exclusions. The prevailing wage laws that apply to local governmental units and their contractors are §§66.0903 and 103.503, Wis. Stats. The prevailing wage laws that apply to state agencies and their contractors are §§103.49 and 103.503, Wis. Stats. The applicable administrative rules for all prevailing wage projects are DWD 290 and DWD 294, Wis. Adm. Code. These laws include provisions that apply to all contractors and subcontractors working on prevailing wage projects.

Any contractor or subcontractor working on a local governmental unit or state agency's public works project that equals or exceeds current prevailing wage project thresholds must do all of the following:

- Receive and review the project's prevailing wage rate determination (i.e., white sheet).
- Tell subcontractors the project is subject to state prevailing wage law and include the prevailing wage rate determination in the construction contract, or if there is no written contract, provide a copy of the project determination to each subcontractor.
- Hire subcontractors who do *not* appear on the "Consolidated List of Debarred Contractors."
- Have a written substance abuse testing program in place that fulfills the requirements of §103.503, Wis. Stats., before commencing work on the project.

- Notify subcontractors that if DWD finds that a contractor or subcontractor violated the prevailing wage law, DWD will assess liquidated damages of 100% of the wages owed to employees.
- Apply to DWD for subjourney wage rates prior to employing these individuals on the project.
- Receive and retain a completed Affidavit of Compliance from each subcontractor brought on to the project before providing final payment to those subcontractors.
- Submit a completed Affidavit of Compliance to the contractor who brought the subcontractor on to the project before receiving final payment for the project.
- Maintain payroll records for 3 years that comply with §§66.0903(10)(a) or 103.49(5)(a), Stats. and DWD 274.06.
- Respond to requests from DWD or the project owner to provide payroll records and/or respond to prevailing wage complaints filed by employees or third parties.

For more information, visit the prevailing wage website: http://dwd.wisconsin.gov/er/prevailing_wage_rate/default.htm. For further assistance, call the Equal Rights Division at 608-266-6861 and ask for prevailing wage.